

TIRE DEALERS

Maximize Uptime With The Industry's Most Durable Products

70X-3 RIM CLAMP® TIRE CHANGER

Advanced Features and
a Best-in-Class External
Clamping Range



Patented Robo-Arm® Helper Device



Device assists in efficiently changing low profile or run flat tires. Robo-Arm® assist provides direct pressure to create a bead lock and keep the bead in the drop center during the tire mount process.

Single Point Sealer



This feature concentrates air flow to seal the beads more efficiently and eliminates excessive maintenance.

Hand-Actuated Bead Loosener



The Bead Loosener offers point of use controls to the technician, providing direct line of site, reducing the risk of wheel damage.

To learn more about the Coats 70X-3 tire changer, or any of our other quality products, contact your authorized Coats distributor or call **1-855-876-3864** for the dealer nearest you.

COATS®

CONTACT US NOW

www.coatsgarage.com
or call 1-855-876-3864



70X-3 RIM CLAMP® TIRE CHANGER

70X-3 RIM CLAMP® TIRE CHANGER

BUILT FOR HIGH-VOLUME SHOPS

SPECIFICATIONS

Wheel Handled	Alloy and Steel for Car and Light Truck
Rim Diameter	6" - 24" External
Maximum Tire Diameter	50" Max
Maximum Rim Width	14" Max
Bead Loosening System	Hand or Foot Control, Up to 14" Wide
Wheel Clamping System	4 Clamps, Air Cylinder Operated
Mount/Demount Mechanism	Swings Away for Better Access and Durability
Helper Devices	Robo-Arm® (18" of Automated Vertical Stroke)
Bead Seating Air Volume	5.4 Gallons in Tower
Inflation Gauge	0 - 60 psi
Air Supply Gauge	0 - 300 psi
Air Drive System	1.5 HP Air Motor, 110 - 175 psi, 15 scfm (Air Model Only)
Electric Drive System	1 HP Electric Motor, 115 V, 60 Hz, 15amp (Electric Model Only)
Footprint	49"w x 48"d x 85"h
Ship Weight	700 lbs.
Warranty	3 Year Parts, 6 Months Labor
Part Number	Air Hand Model: 80070XAH3 Electric Hand Model: 80070XEH3 Air Foot Model: 80070XAF3 Electric Foot Model: 80070XEF3

EQUIPMENT FOOTPRINT

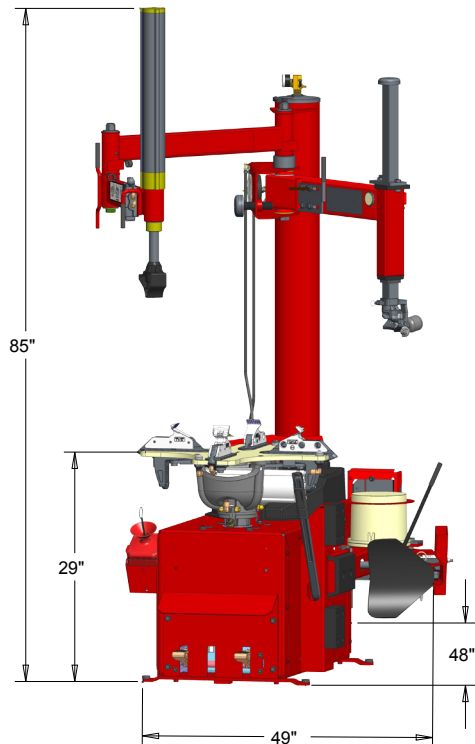

ACCESSORIES

* Included With Purchase

Part Number	Description
*8183606	Bead Loosener Shoe Socks - 2
*85009048	Paste Lube Bracket & Brush
*8183710	Paste Lube
*8560716108	Grip-Max® Plus Grips - 8
*8184432	Grey High Spoke Duckhead® Mount/Demount Tool
*8182961	Duckhead® Mount/Demount Tool Inserts - 2
*85000783	Lift Tool Socks - 10
*85610105	Premium Storage Cabinet
*85609077	Manual Bead Depressor Kit
*85607787	Grip-Max® Plus Clamps - 4
*8183061	Plastic Duckhead® Mount/Demount Tool
85608959	Hybrid Duckhead® Mount/Demount Tool

RECOMMENDED OPTIONAL ACCESSORIES



EL-X Express Lane®
Inflation System
(PN 85607770)



Grip-Max® Plus
28" Clamps
(PN 85607986)

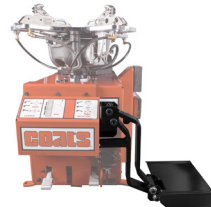

Point-of-Use Lift System
(PN 85608609)



Manual Drop
Center Tool
(PN 8435685)



Auxiliary Bead Sealer (ABS)
(PN 85606545)



Paste Lube Bucket
(PN 8183710)

COATS®