

CEMB[®] USA

ER75TD HubMatch[®]

A high volume RFV (Radial Force Vectoring) diagnostic wheel balancer that uniquely uses advanced balancing features such as our Dynamic AutoAdaptive with OPB balancing and RFV measurement combined with HubMatch; a guided on-car eccentricity cancellation process which significantly reduces floor-to-floor cycle time and provides an improved ride quality to eliminate the most difficult tire and wheel related vibration problems.

www.cemb-usa.com



PROUDLY DISTRIBUTED BY



ER75TD HubMatch™



AutoAdaptive Mode

detects weight and dimensions and calculates the tolerance value that will cancel any vibration perceived on the steering wheel.

ER75TD Versions

comes in both manual-clamping and auto-clamping (shown here)

OPB: One Plane Balancing

eliminates both static and dynamic unbalance with a single counterweight, indicating the exact position to apply the weight inside the rim

Spotter Laser System

pinpoints the exact position for stick-on weights inside the rim

HubMatch™

detects the unbalance as well as the highest point of the wheel (1st harmonics), and displays it on-screen to enable mounting of wheel on vehicle

Zeroweight Lift

zero gravity effect wheel loading and removal lift, standard with auto-clamping version.



DIMENSIONS

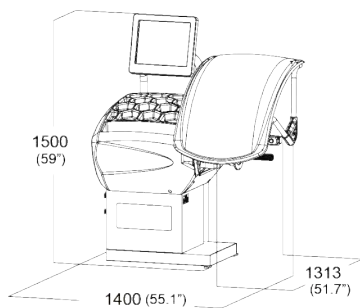

CONTACT

Power Supply:	110/220V, 1ph, Air
Wheel Clamping Type:	Auto/Manual
Max. Rim Diameter:	30" (765 mm)
Max. Rim Width:	20" (510 mm)
Max. Tire Diameter:	42" (1065 mm)
Max. Wheel Weight:	165 lbs. (75 kg)
Shipping Weight:	375 lbs. (170 kg)

CEMB® USA

CEMB USA - BL Systems Inc.
2873 Ramsey Road, Gainesville, GA 30501
(678) 717-1050 - sales@cemb-usa.com
www.cemb-usa.com