

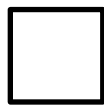

# *PRO SERIES TOOLS*

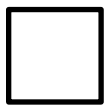

*TECH 300 PRO TECH 300 PRO C TECH 400 PRO*



# USER GUIDE

Welcome to the Bartec TPMS Family! Hopefully you will find our tool and support to be the best! Please take a few moments to review this user guide in its entirety for instructions on all the features you find in your new PRO Series Tool.

## TABLE OF CONTENTS

<b>IMPORTANT NOTICES</b> .....	3	3.5 PERFORMING A TBYT .....	22	8.4 SOFTWARE UPDATES (400PRO ONLY) .	41
<b>KIT CONTENTS</b> .....	4	3.6 TBYT TOOLKIT.....	25	8.4.1 WiFi Updates .....	41
<b>1.0 GETTING STARTED</b> .....	4	<b>4.0 PROGRAM SENSOR</b> .....	26	8.4.2 Enter Update Mode .....	41
1.1 TOOL LAYOUT AND CONNECTIONS .....	5	4.1 PROCEDURE .....	26	8.5 TOOL INFO .....	42
1.2 POWER ON/OFF .....	5	4.2 CONTACT SENSORS .....	26	8.6 ENTER UPDATE MODE (300PRO ONLY)	42
1.3 CHARGING .....	6	<b>5.0 RELEARN</b> .....	27	8.7 USAGE .....	42
1.4 TOOL SETUP .....	7	5.1 STATIONARY RELEARNS.....	27	8.8 SUPPORT .....	42
1.5 INSTALLING TPMS DESKTOP .....	7	5.2 ACTIVE (DRIVE) RELEARNS .....	28	<b>9.0 TPMS DESKTOP</b> .....	43
1.6 REGISTERING YOUR TOOL .....	8	5.3 OBDII RELEARNS (300PROC AND	28	9.1 TPMS DESKTOP UPDATES .....	43
1.7 BLUETOOTH SETUP .....	10	400PRO ONLY) .....	28	9.2 AUDITS.....	44
1.8 WI-FI SETUP (400PRO ONLY) .....	10	5.4 OBDII ASSISTED RELEARNS (MITSUBISHI	30	9.3 PLACARD (400PRO ONLY) .....	44
1.9 UPDATING YOUR TOOL.....	11	ONLY).....	30	9.4 UPDATES .....	45
1.9.1 TPMS Desktop Method .....	11	5.5 INDIRECT SYSTEMS.....	31	9.5 VEHICLE LOOKUP.....	45
1.9.2 PC Method .....	11	5.6 RELEARN TOOLKIT .....	31	9.6 SETTINGS .....	46
1.9.3 SD Card Method .....	13	<b>6.0 VEHICLE DATA</b> .....	32	9.7 PAD .....	46
1.10 OBDII MODULE UPGRADE (300PRO	14	6.1 UPLOAD STORED DATA.....	32	9.8 TECHNICAL SUPPORT.....	46
ONLY).....	14	6.2 REVIEW DATA.....	32	<b>10.0 TOOL SERVICE</b> .....	46
<b>2.0 USING YOUR PRO SERIES TOOL</b> .....	15	<b>7.0 TOOLKIT</b> .....	32	10.1 PROPER CARE AND CLEANING .....	46
2.1 TOOL NAVIGATION .....	15	7.1 PLACARD CHANGE (400PRO ONLY)..	33	10.2 SERVICE.....	47
2.2 TOOL DISPLAY AND ICONS.....	16	7.2 RKE TEST .....	34	10.3 ACCESSORIES AND REPLACEMENT PARTS	48
2.2.1 Menus.....	16	7.3 UHF MONITOR.....	34	.....	48
2.2.2 Operations Screen .....	17	7.4 PASSIVE KEY (400PRO ONLY).....	35	<b>11.0 TECHNICAL SUPPORT</b> .....	51
2.3 TOOL POSITIONING/READING A SENSOR	17	7.5 UNLOCK REDI 7002A .....	35	<b>12.0 APPENDICES</b> .....	52
2.3.1 Standard LF Activation .....	17	<b>8.0 MY TOOL</b> .....	35	A - GLOSSARY .....	52
2.3.2 Magnet Activation.....	18	8.1 SETTINGS .....	36	B - VIN .....	54
2.3.3 $\Delta p$ (Lowering Pressure)	18	8.2 WiFi (400PRO ONLY).....	37	C - FAQ & TROUBLESHOOTING GUIDE ....	55
Activation .....	18	8.3 BLUETOOTH .....	37	D - COMS ERROR TROUBLESHOOTING ....	56
2.3.4 Sensor Responses.....	19	8.3.1 Enabling Bluetooth .....	38	<b>LIMITED WARRANTY AND REPAIR</b> .....	57
<b>3.0 TEST BEFORE YOU TOUCH (TBYT)..</b>	20	8.3.2 Pair to a PC .....	38	<b>TOOL REGISTRATION FORM</b> .....	59
3.1 TPMS LIGHT STATUS.....	20	8.3.3 Pair to a Bluetooth Printer. ....	40		
3.2 PHYSICAL/MECHANICAL INSPECTION..	21	8.3.4 View Paired Devices.....	40		
3.3 SENSOR ACTIVATION .....	21				
3.4 OBDII DATA (WHERE SUPPORTED) ...	22				

## Important Notices

### COPYRIGHT

No part of this manual may be reproduced, stored in a retrieval system or transmitted, in any form or by any means - electronic, mechanical, photocopying, recording, or otherwise - without prior written permission from Bartec.

### DISCLAIMER

Bartec makes commercially reasonable efforts to provide accurate and complete data in connection with our tools and our website, but the volume of data compiled and the variety of sources from which the data comes makes it impossible to warrant full accuracy or completeness of any kind. AS A RESULT, BARTEC DOES NOT WARRANT, AND SPECIFICALLY DISCLAIMS ANY WARRANTY, THAT THE SITE, TOOLS, AND/OR THE CONTENT CONTAINED THEREIN IS ACCURATE OR COMPLETE.

All specifications, illustrations and information contained within this manual are based on the most current information available at the time of publication. Bartec USA reserves the right to make changes at any time without obligation to notify any person or organization. Bartec USA will do its best to keep you the customer informed of any changes that might affect the tools performance. Important items will be called out by using “**NOTE.**” Information following this indication should always be paid attention to.



**Whenever you see this symbol, the information you are about to read is vitally important and should be committed to memory.**

### FCC COMPLIANCE

FCC ID: SX8T500      IC: 5736AT500  
Contains FCC ID: QOQWT12      IC: 5123A-BGTWT12A  
Contains FCCID: YOPGS1011MIPIC: 9154A-GS1011MIP

*This device complies with Part 15 of the FCC Rules and with Industry Canada license-exempt RSS standard(s). Operation is subject to the following two conditions: (1) This device may not cause harmful interference, and (2) This device must accept any interference received, including interference that may cause undesired operation.*

*Le présent appareil est conforme aux CNR d'Industrie Canada applicables aux appareils radio exempts de licence. L'exploitation est autorisée aux deux conditions suivantes : (1) l'appareil ne doit pas produire de brouillage, et (2) l'utilisateur de l'appareil doit accepter tout brouillage radioélectrique subi, même si le brouillage est susceptible d'en compromettre le fonctionnement.*

*Note: Changes or modifications not expressly approved by the party responsible for compliance could void the user's authority to operate the equipment.*

## Kit Contents

Item	WRT300PRO	WRT300PROc	WRT400PRO
PRO Series TPMS Tool	✓	✓	✓
SD Card (in tool)	✓	✓	✓
Qi Inductive Charging Pad with Power Supply			✓
Standard Wall Plug Power Supply	✓	✓	
Bluetooth USB Dongle (Adapter)	✓	✓	✓
Relearn Magnet (for early-model GM vehicles with sensors)	✓	✓	✓
Mini USB Cable	✓	✓	✓
DB15 to OBDII Cable		✓	✓
Quick Start Guide	✓	✓	✓
Master Kit CD	✓	✓	✓

## 1.0 Getting Started



Please register your tool on the Bartec website at [www.bartecusa.com](http://www.bartecusa.com) (see [Section 1.7](#) for more details). This is the best way to get information about software updates, new products and other important TPMS news. Bartec respects your information and keeps it private!

## 1.1 Tool Layout and Connections

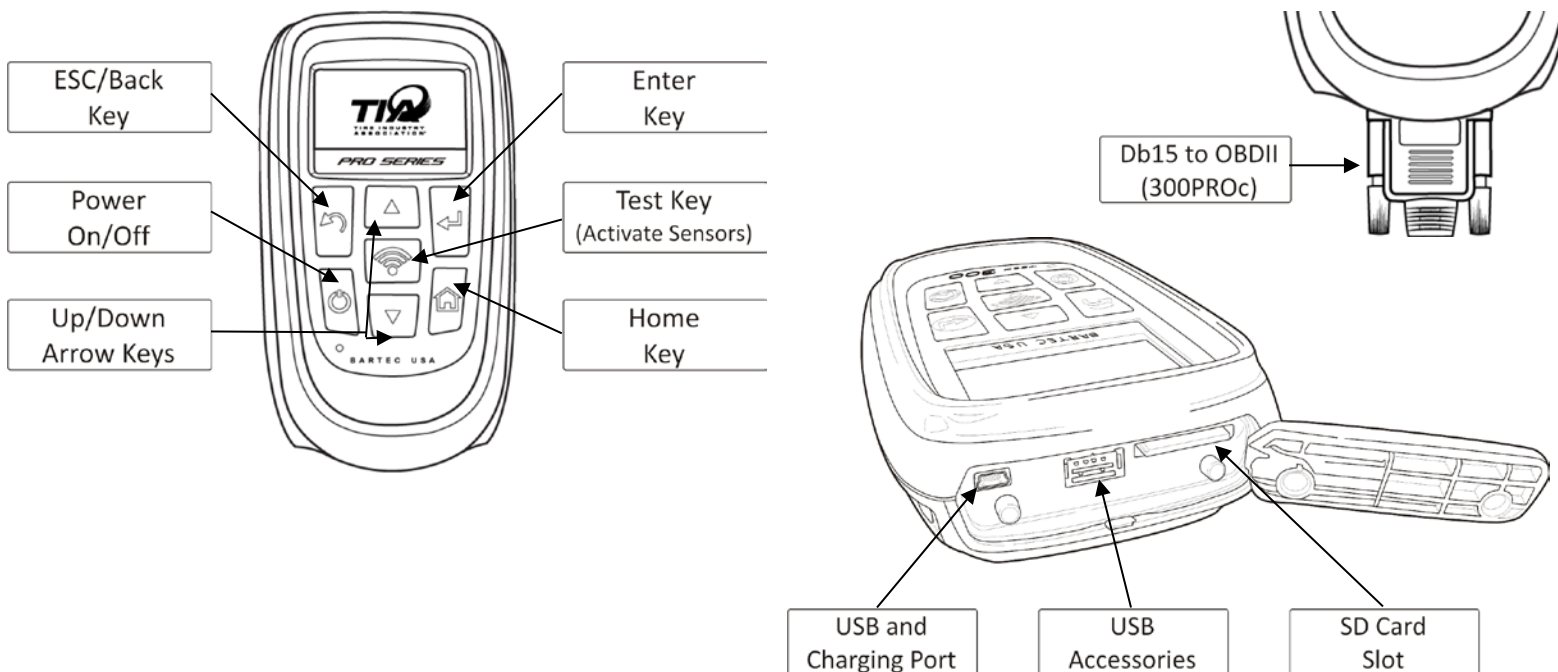

## 1.2 Power On/Off

The PRO Series tool is powered on by a single press of the On/Off key. Upon power-up, the screen displays the Bartec logo.

The PRO Series tool will enter Power Save mode automatically after 3 minutes of inactivity, and automatically shut off after 5 minutes of inactivity. To power the tool off at any time, press and hold the On/Off key for approximately 2 seconds; a “Goodbye” message will flash, and the tool will shut off.

**NOTE:**

The PRO Series tool automatically powers on when the charger or USB port is in use. Auto shut-off is not operational during this time.

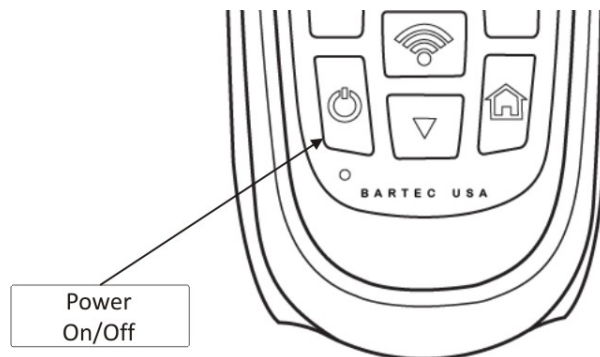

### 1.3 Charging

Your PRO Series tool comes with a factory-installed rechargeable battery. **Battery replacement must be done at the Bartec USA Repair facility** (see [Section 10.2](#) for battery service). When the charging cradle or mini USB cable is in use, the tool automatically powers up, and auto shut-off is not operational.

**NOTE:**

For optimum performance, always keep your tool charged.

The PRO Series tool is shipped with a fully charged battery. However, it is recommended that you charge your tool for at least four (4) hours before using.



**DO NOT** apply metallic labels here!



**Do not attach metallic items of any kind to the charging area.**

#### Charging Methods:

Item	WRT300PRO	WRT300PROc	WRT400PRO
Qi Inductive Charging Pad with Power Supply	Sold Separately	Sold Separately	✓
Standard Wall Plug Power Supply	✓	✓	Sold Separately
Mini USB Cable	✓	✓	✓

The Qi Inductive Charging Pad is the preferred method of charging. You can also use the supplied mini USB cable attached to either the Standard Wall Plug Power Supply or a PC. Only use the power supply or mini USB cable that is included in the PRO Series kit to charge this tool.

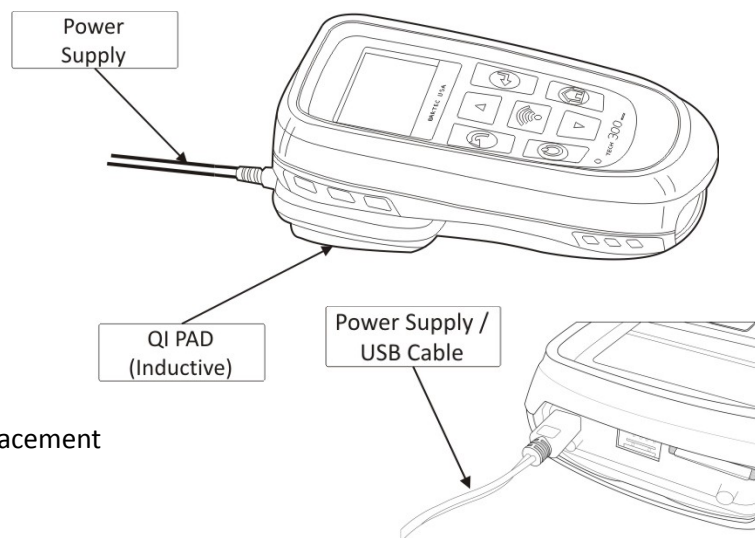

**Use of unapproved power supplies may damage your tool and will void the warranty.**

See [Section 10.3](#) for part numbers when ordering additional/replacement accessories.

## 1.4 Tool Setup



Before using your new PRO Series tool, the internal clock must be set correctly to ensure your audit data has the correct date/time stamp. This allows proper sharing of information to TPMS Desktop and easy management of your audit data.

The **Date/Time** settings can be configured under **My Tool > Settings**. See [Section 8.1](#) for more details.

## 1.5 Installing TPMS Desktop

The TPMS Desktop application is required to use the wireless features of the PRO Series tool. Once installed and running, TPMS Desktop will help you keep your tool updated, organize audit reports, and manage your customers, all from a single access point. This application is discussed in greater detail in [Section 9.0](#).



**TPMS Desktop must be installed on a PC BEFORE the Bluetooth or Wi-Fi features of the PRO Series tool can be used.**

To install TPMS Desktop on your PC or tablet, run the Master Kit CD provided with the PRO Series tool and select **TPMS Tools > TPMS Desktop Software**, or download the latest software by [clicking here](#).



Double-click the downloaded **setup.exe** file, then click **Run** on any security prompts to start the installation.

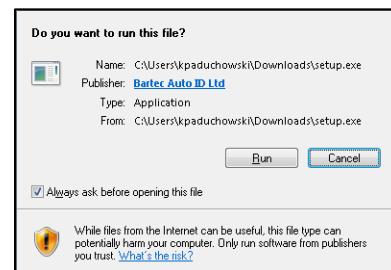

## 1.5 Installing TPMS Desktop (Continued)

The install wizard will advise you of the installation status. Follow the onscreen instructions. TPMS Desktop will launch automatically upon completion.

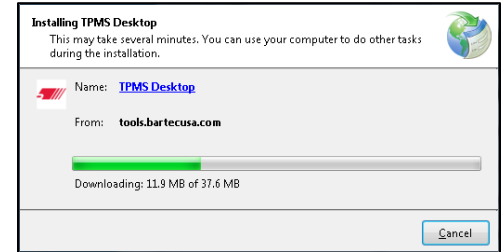

## 1.6 Registering Your Tool

The registration process can be started by clicking the **Register Tool** link in TPMS Desktop.



Alternately, you can navigate to [www.bartecusa.com](http://www.bartecusa.com), click the **Register Tool** link, and then click **TPMS Support Center** on the following page.



## 1.6 Registering Your Tool (Continued)

On the TPMS Support Center page, for new users, click the “**click here to register**” link to create a new account and submit the required information.

Users with existing accounts can use the **Log on** field to sign in with their username and password.



Once you are signed into TPMS Support Center as a new or existing user, click **Register Tool** from the top menu and submit the required information.

**NOTE:**

Please allow one business day for tool registration to be completed).



## 1.7 Bluetooth Setup

All PRO Series tools can be paired to a PC with Bluetooth capabilities, allowing you to send audit data wirelessly to the TPMS Desktop application (see [Section 9.0](#) for details on TPMS Desktop). You can also pair your tool to the Bartec Wireless Bluetooth Printer accessory (sold separately – see [Section 10.3](#) for part number) for quick and easy printing of audit data.

For your convenience, a Bluetooth dongle is included in every PRO Series tool kit. The dongle is to be used with PCs that do **NOT** have internal Bluetooth capabilities. Follow the installation and setup instructions that are included in the Bluetooth dongle packaging.



**Do NOT use the included Bluetooth dongle if your PC already has internal Bluetooth capabilities. Using both may cause conflicts with Bluetooth drivers and interfere with Bluetooth communications.**



**Insert the Bluetooth installation CD BEFORE connecting the Bluetooth dongle to the PC.**

Refer to [Section 8.2.2](#) for information on pairing your PRO Series tool to your PC and Wireless Bluetooth Printer.

## 1.8 Wi-Fi Setup (400PRO Only)

For publicly broadcasting WiFi networks, see [Section 8.2.1](#) for instructions on connecting to WiFi using your 400PRO tool.

For private, non-broadcasting WiFi networks, you can connect to WiFi via the **Tool Wireless Config** application. You can download this application by clicking here: [http://tpmstopgun.com/wifi\\_tool.php](http://tpmstopgun.com/wifi_tool.php)

Or access it through TPMS Desktop by clicking on **Technical Support**, then selecting the **WiFi** tab on the proceeding page.



BARTEC USA	
SSID (Network Name)	<input type="text"/>
Mode	infra
Security	<input type="text"/>
DHCP	Enabled
Passphrase (Password)	<input type="text"/>
<b>Save Config</b>	

## 1.8 Wi-Fi Setup (400PRO Only) (Continued)

To configure your tool to connect to your Wi-Fi network, you will need to know your:

- SSID (Network Name)
- Security Type (WEP, WPA, WPA2)
- Password

Enter the required information, then connect your tool to the PC via the supplied mini USB cable. The application will recognize the tool and save the configuration directly to it once the **Save Config** button is clicked.

## 1.9 Updating Your Tool

Once your tool is registered, verify the current software version on the tool is the latest version available, and update your tool if necessary. Updating your PRO Series tool can be done in three ways, as detailed in the following sections.

1. **TPMS Desktop** method (recommended)
2. **PC** method (alternate method sometimes used by Technical Support)
3. **SD Card** method (used by users without regular internet access)

### 1.9.1 TPMS Desktop Method

It is easiest and fastest to use TPMS Desktop to update your PRO Series tool; see [Section 9.4](#) for complete details).

### 1.9.2 PC Method

**NOTE:**

PRO Series tools are compatible with PCs running Windows operating systems (Windows 7 or newer). USB ports can be either version 1 or 2. Ensure you do not have any other programs open/running during this process.

Log into your TPMS Support Center account (see [Section 1.6](#)) and click the **Tool Management** link.

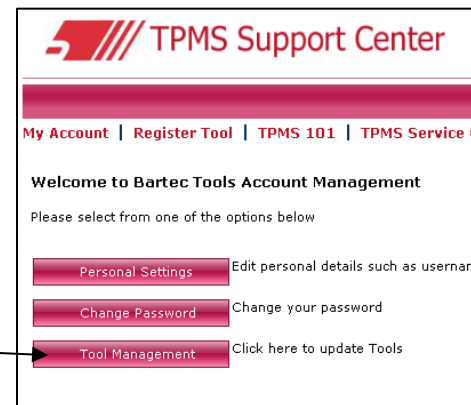

### 1.9.2 PC Update Method (Continued - 2)

If the software version listed under the **Update** column is higher than the version on your tool (use **My Tool > Tool Info** to view on the tool), click the green **Download** link and save the update file (\*.mfu) to your PC.

Personal settings Change password Tools						
Click 'Training' tab for more information on Updates.						
Tool	Serial No	Version	Supplier	Registered	Expires	Update
TECH300SDC	880322		BUSA	08-01-2016	08-01-2017	DownloadV55.0
Register Tool		Register Software Certificate		Register Hub Certificate		Hub L

Power your PRO Series tool on, and from the Home menu, select:

**300PRO:** My Tool > Enter Update Mode

**400PRO:** My Tool > Software Updates > Enter Update Mode

The tool will display “Insert USB Lead to Transfer Update Files”.

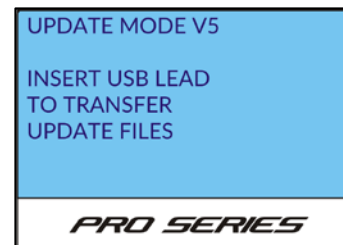

Connect the mini USB cable to a USB port on the PC, then to the PRO Series tool via the USB port under the top cover. Once Windows detects and installs the drivers for your tool, this should access the tool’s SD card by opening a Removable Disk window on your PC.

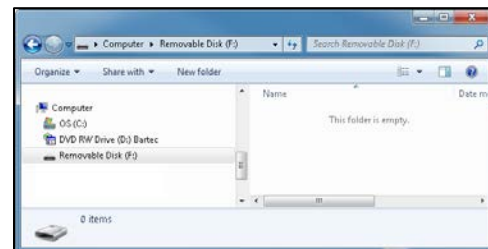

Copy/paste or drag and drop the saved update file (\*.mfu) into the Removable Disk window. Once file copying is completed, disconnect the USB cable from the tool.

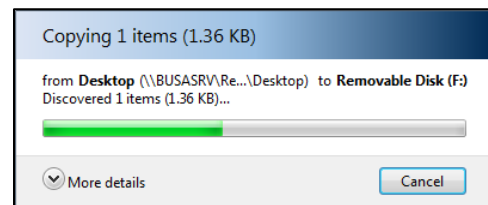

Once the tool is disconnected from the PC, it will automatically load the new update file to its operating system. Once the automatic update is completed, the tool will shut itself off.

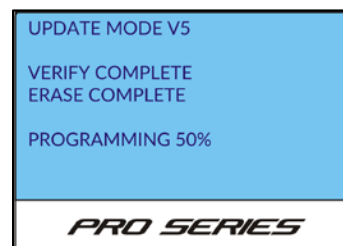

### 1.9.3 SD Card Method

**NOTE:**

In order to receive updates by SD card, you must request to be part of the SD card program.

Open the rubber boot on the top of the tool. Remove the old SD card by pushing down to release it, then removing it from the SC card slot. Keep the old SD card separate from the new one.

Insert the new SD card in the slot and push down until it clicks to lock in place. Power your PRO Series tool on, and from the Home menu, select:

**300PRO:** My Tool > Enter Update Mode

**400PRO:** My Tool > Software Updates > Enter Update Mode

The tool will display “Insert USB Lead to Transfer Update Files”.

The tool will now load the update file to its operating system. Once the update is completed, the tool will shut itself off.

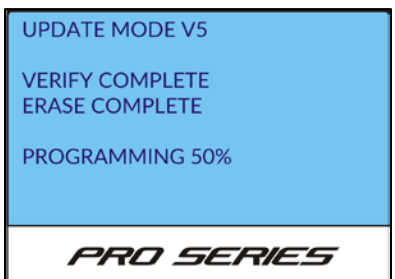
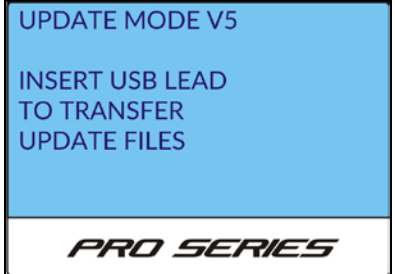
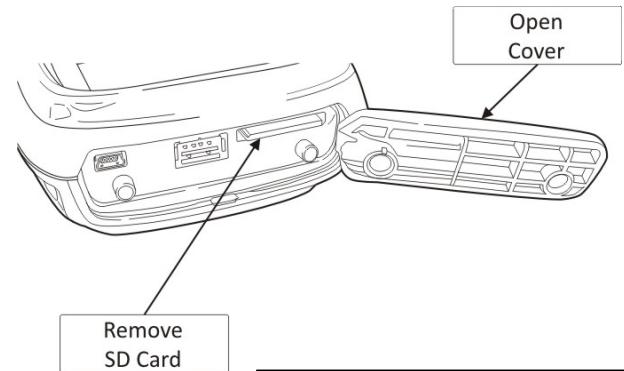

## 1.10 OBDII Module Upgrade (300PRO Only)

The Tech300PRO tool can be upgraded to add OBDII communications and functionality by purchasing and installing the OBDII Upgrade Kit (see [Section 10.3](#) for part number).

To install the OBDII Upgrade Kit to your Tech300PRO:

1. Remove the base plate (stamped with **OBD**) from the bottom of your tool. This is most easily done by inserting a small flathead screwdriver into one of the holes and gently prying it up until it releases.

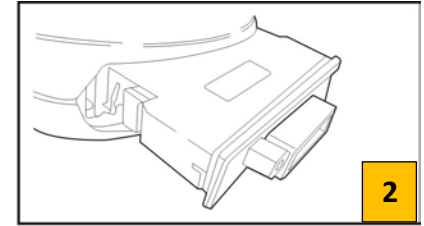

2. With your tool face up, insert the module with the longer 8-pin row of the OBDII connector at the bottom.

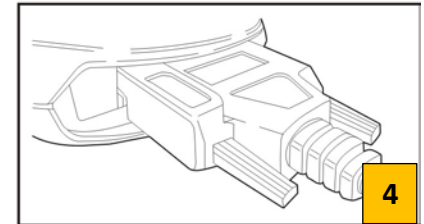
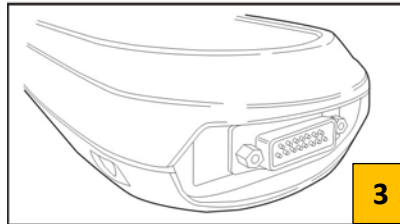

3. Once the module is properly oriented, place the tool on edge and use both thumbs to push until the module is fully seated and snaps into place.

4. Connect the OBDII cable when you are ready to connect to a vehicle. Turn the thumbscrews until they are finger-tight to ensure a good connection.

5. Apply the supplied mylar sticker to the bottom of the tool around the installed module.

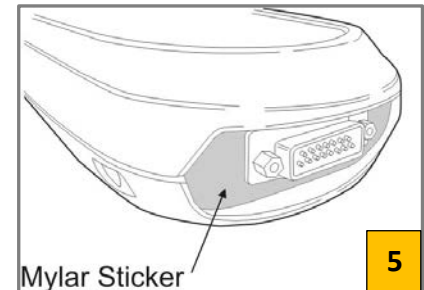







**NOTE:**

Once the OBDII module is inserted, the Tech300PRO automatically recognizes the hardware change and will provide OBDII connection options when relevant to the function you are performing, such as obtaining OBDII data during Test Before You Touch (see [Section 3.4](#)) or performing OBDII Relearns (see [Section 5.3](#)).

## 2.0 Using Your PRO Series Tool

These sections will help you to familiarize yourself with navigating the class-leading features of your PRO Series tool.

### 2.1 Tool Navigation

	<b>Up/Down Arrow Keys</b>	Navigates within the current menu
	<b>ENTER Key</b>	Navigates to the next menu or actions the currently selected item
	<b>Back/ESC Key</b>	Navigates to the previous menu item
	<b>Test Key</b>	Starts a TPM test (Activation) when on the Operations Screen
	<b>Home Key</b>	Returns to the Home menu
	<b>Power Key</b>	Powers the tool on and off

## 2.2 Tool Display and Icons

### 2.2.1 Menus

The PRO Series tool's menu system provides a hierarchy of instructions and commands. The top line of the display will always indicate the current menu selected. The Home key will always return to the Home menu with **Test Before You Touch** highlighted.

**Number of Selections:** Indicates the menu item currently displayed. The first number indicates the item selected, and the second number indicates the total number of menu selections available.

**Current Selection:** Highlighted items will be actioned when pressing the Enter key.

**Data Stored:** Indicates data is currently stored on the tool.

**Battery Indicator:** Indicates the remaining charge status of the battery (see [Section 1.3](#) for details).

**NOTE:**

Because different TPMS systems use different levels of energy, the Battery Indicator only provides estimates of remaining battery life left before charging is required.

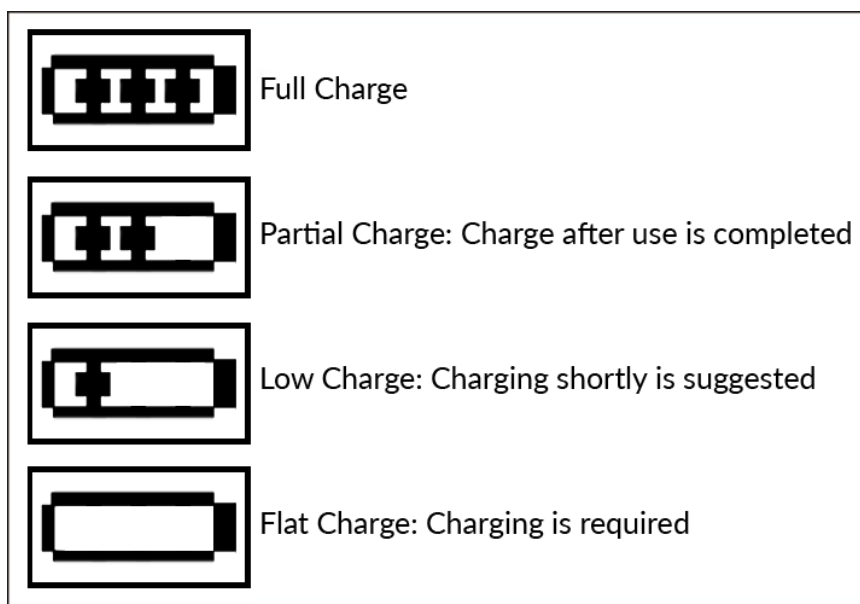
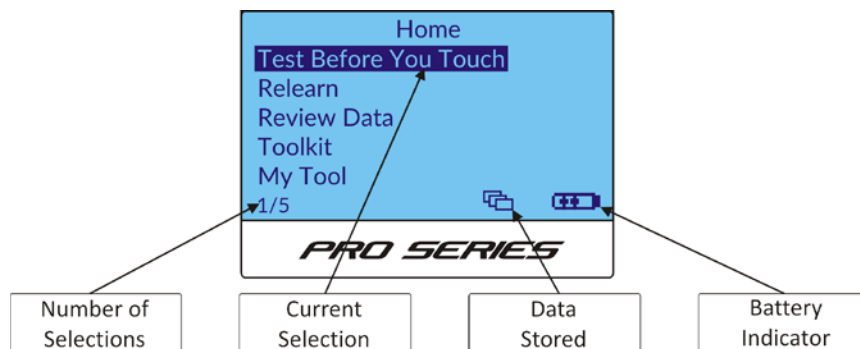

### 2.2.2 Operations Screen

The Operations screen is where you will complete all sensor testing and relearn steps. The Arrow icon indicates your current wheel position or icon selection.

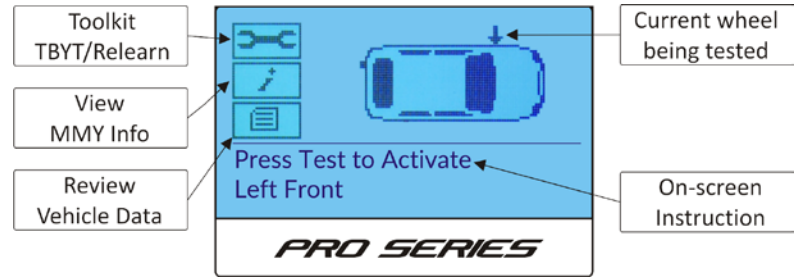

### 2.3 Tool Positioning/Reading a Sensor

Proper tool positioning is important to ensure sensor reading and activation. The following sections will illustrate the different sensor activation methods.

#### 2.3.1 Standard LF Activation

**Snap-in Sensors:** Place the PRO Series tool on the tire, aimed towards the TPMS sensor location (near the valve stem) as shown below.

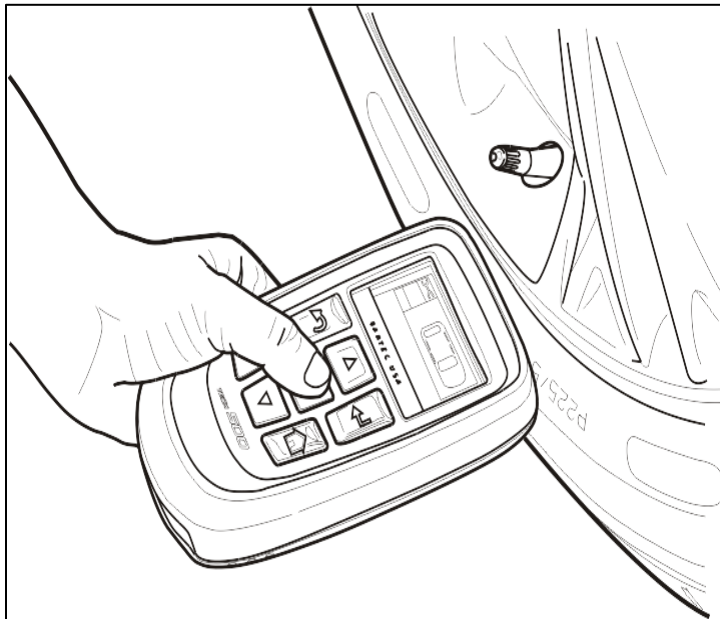

**Banded Sensors (e.g. Ford):** Place the PRO Series tool on the tire, held 180° opposite of the valve stem as shown below.

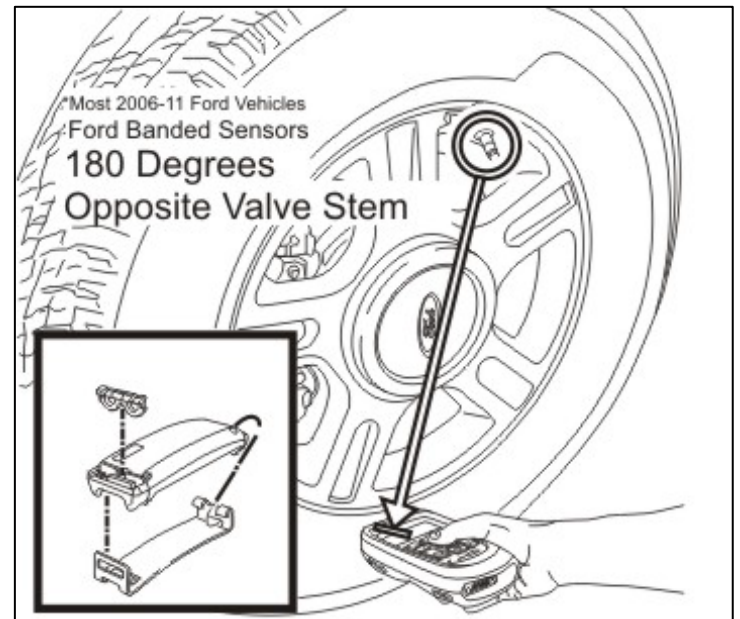

### 2.3.2 Magnet Activation

If the procedure requires a magnet, the tool will instruct the user to “Place magnet on stem”.

Place the magnet from your PRO Series kit over the valve stem, position the tool alongside the stem, and press the Test key.

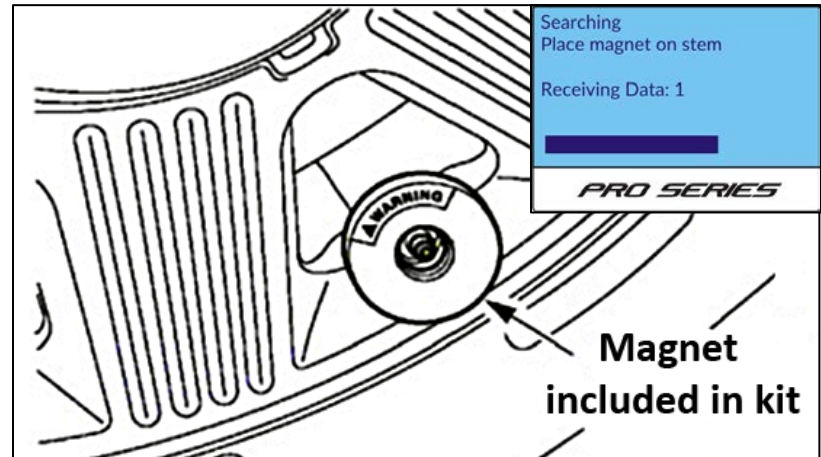

### 2.3.3 $\Delta p$ (Lowering Pressure) Activation

If the sensor requires tire deflation (minimum of 10psi), the tool will instruct the user to “Reduce Pressure”.

Position the tool alongside the valve stem. Begin releasing air from the tire accordingly (this is easiest when using an approved tool to press the valve core), and press the Test key on the tool.

**NOTE:**

If the tool fails to read on the first try, continue releasing air pressure and press Test again.

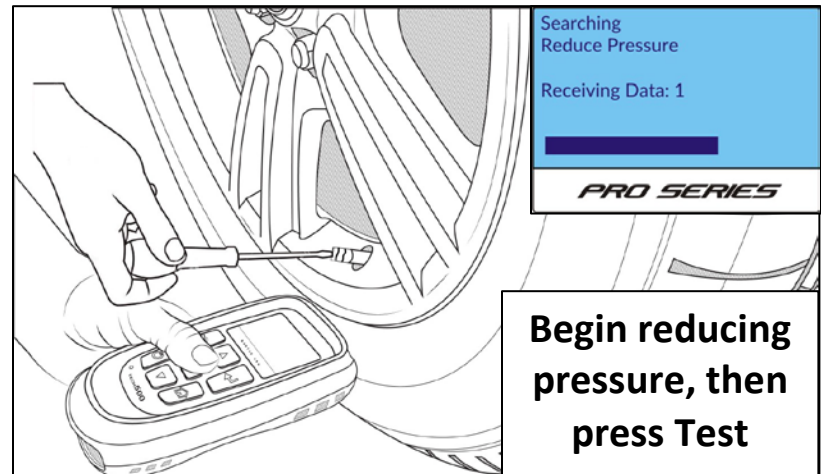

### 2.3.4 Sensor Responses

On the Operations screen, there are four possible results that can be displayed at a wheel position after scanning a sensor:

#### ## = Successful Read

If a sensor is read successfully, then the Operations screen displays the air pressure readout at that wheel position.

#### ? = Wrong Sensor Found

A “?” displayed at a wheel position means that a sensor that uses the same LF activation as the correct sensor for the Make, Model, and Year selected has been found. Verify the MMY you have selected on the tool is correct, and that the correct sensor part number has been fitted.

#### NOTE:

Because many TPMS sensors can look alike, Bartec recommends checking part numbers instead of a visual inspection of the sensor.

#### X = Failed Read

If the scan period expires without reading a sensor, then the tool will emit three beeps and indicate “Sensor Failure detected”. Pressing Test will attempt another scan, and pressing Enter will continue to the next step in the process. The sensor data will still be stored, but will indicate that the sensor “Failed to Read” if the scan fails 3 times.

When the tool returns to the Operations screen, an “X” will be displayed next to the failed sensor’s wheel position.

#### D = Duplicate ID Found

A “D” indicates that the scanned sensor contains the same ID as another sensor on the vehicle. This error usually occurs when a sensor ID is “copied” versus “created” during programming (see [Section 4.1](#) for sensor programming procedures).

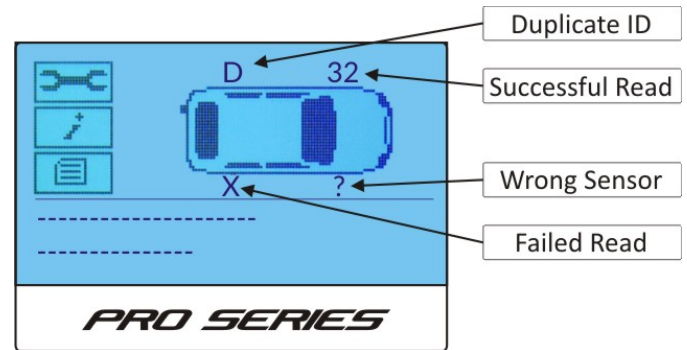

### 3.0 Test Before You Touch (TBYT)

The phrase “Test Before You Touch” (or **TBYT**) is exactly that: understanding the overall condition of the vehicle’s TPMS prior to service. The first recommended step with TPMS service is to conduct the TBYT process first.

Bartec has integrated this process into the PRO Series tools. When performing a TBYT on a vehicle, the user is examining the following conditions:

- Status of the vehicle’s TPMS light
- Physical/mechanical inspection of the sensors
- Activation of the sensors
- Existing TPMS Diagnostic Trouble Codes (Tech300PROC and Tech400PRO only)

**NOTE:**

Not all vehicles are supported for DTC scanning via OBDII connection; follow the on-tool prompts for further details.

The tool’s **Test Before You Touch** function will prompt the user step-by-step through getting a status of the vehicle by verifying the sensors are working and (when supported) view any TPMS-related Diagnostic Trouble Codes (DTCs).

### 3.1 TPMS Light Status

Understanding the status of the vehicle’s TPMS malfunction indicator light (MIL) is essential in TPMS diagnostics.

**NOTE:**

It is best to check the TPMS MIL status *when first keying on the vehicle*. Some vehicles’ systems may initially display a flashing light at key-on, but change to a solid light after a set interval.



**Solid MIL:** Indicates low air pressure detected in one or more tires. Check and verify that the air pressure of all tires is set to placard.

**Flashing MIL:** Indicates a TPMS system issue. Some example issues:

- Bad or missing sensor
- Sensor not learned to vehicle
- Sensor in wrong mode
- Receiver or control module issue
- Other system issue

### 3.2 Physical/Mechanical Inspection

Check for any of the following conditions:

- Does the sensor have a dust cap?
- Is there any visible corrosion?
- Is the valve stem intact?
- Does any other visible damage exist?

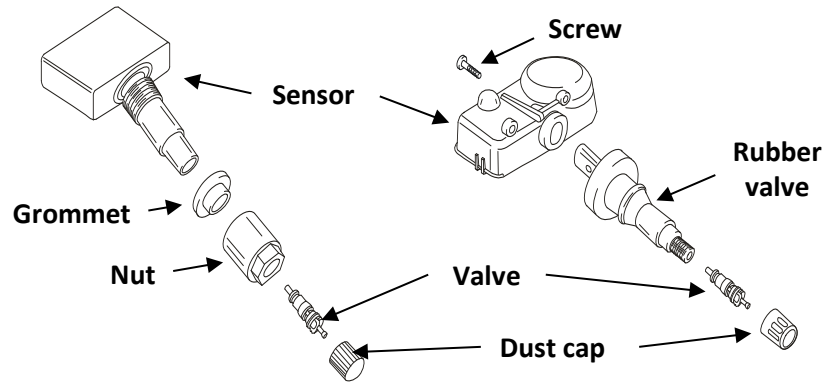

### 3.3 Sensor Activation

What the tool is checking during the TBYT function:

- Proper LF activation and UHF decode based on MMY
- Sensor is transmitting properly
- Pressure and temperature
- Battery status
- Sensor mode

**NOTE:**

It is possible to have one or more non-functioning sensors and have NO TPMS MIL lit; some systems can take over 100 miles and several days to report a fault.

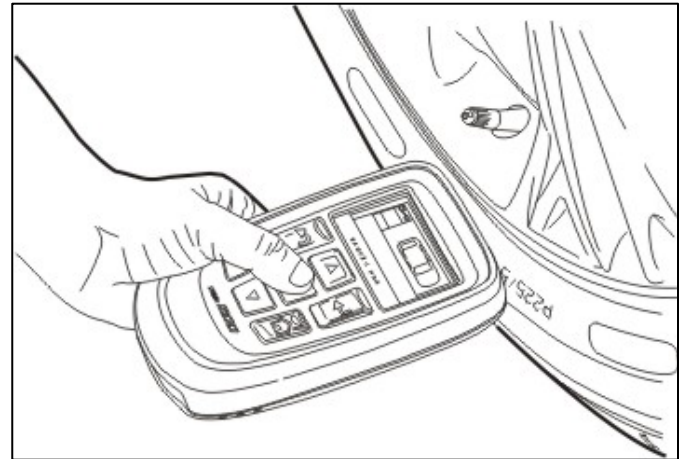

### 3.4 OBDII Data (Where Supported)

PRO Series tools equipped with an OBDII connection will extract the following information from supported vehicles during a TBYT:

- DTCs (Diagnostic Trouble Codes)
- Stored TPMS sensor IDs
- VIN (Vehicle Identification Number)

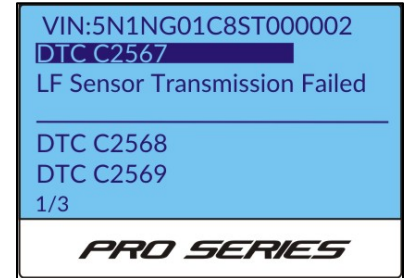

### 3.5 Performing a TBYT

1. On your PRO Series tool, select **Test Before You Touch** from the Home menu.

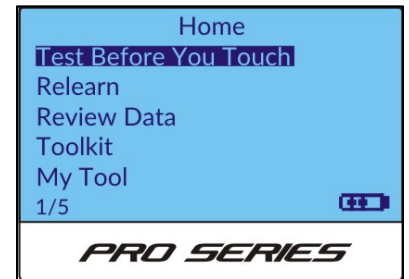

2. Select the Make, Model, and Year of the vehicle you are working on.

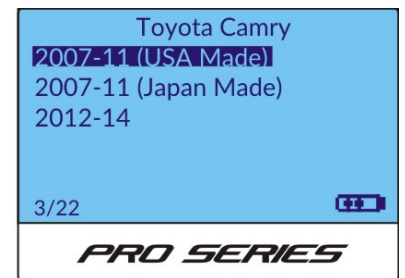

**NOTE:**

Use the 10<sup>th</sup> digit of the VIN to verify the Model Year and ensure accuracy (see [Appendix B](#) for details).

**NOTE:**

If the Year you are working on is not an option, ensure that your tool's software is up-to-date (see [Section 1.9](#)). Contact Bartec Technical Support (see [Section 11.0](#)) to verify whether a work-around exists.

### 3.5 Performing a TBYT (Continued – 2)

- On the Operations screen, the tool will default to the Left Front wheel position and prompt with **Press Test to Activate Left Front**. Position the tool accordingly (see [Section 2.3](#) for proper tool positioning) and press the Test key.

The tool will send the LF signal necessary to activate the sensors for the selected MMY and listen for the correct UHF output from the sensor. Keep the tool in position until the progress bar has completed and the tool indicates the results next to that tire position (see [Section 2.3.4](#) for possible responses).

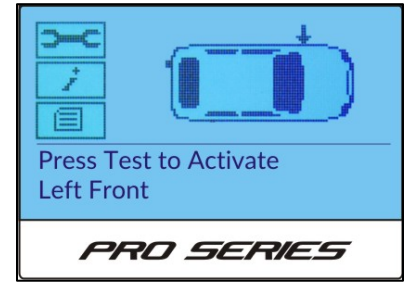

- Continue with the Right Front, Right Rear, and Left Rear as the tool prompts you.

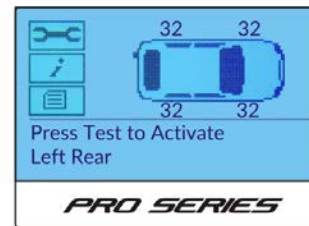

### 3.5 Performing a TBYT (Continued – 3)

5. **(300PROC and 400PRO Only)** If supported, the tool will prompt you to connect to the OBDII port to read out the vehicle information. If not supported, continue to step 6.

**NOTE:**

If ESC is pressed to cancel this portion of the operation, the tool will prompt that OBD can be accessed at a later time via the TBYT Toolkit (see [Section 3.6](#)), and the user may press any key to continue to the next step.



Connect the OBDII cable to the tool and vehicle, then turn the key to the key on/engine off position.

**NOTE:**

If the vehicle has a push-button start, cycle the button until all the accessories (e.g. the radio) are functional.

Once connected, press the Enter key to begin reading the existing sensor IDs, DTCs and other info from the vehicle's control module. The tool will indicate when the scan is completed.

**NOTE:**

If DTCs are read, the tool usually gives a short description of the code; you will need to cross-reference these codes with an external OEM DTC reference to further determine their definitions.

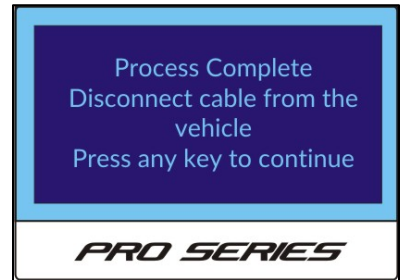

6. The next menu allows the option to **Save** or **Print** data, **Send** data to TPMS Desktop, **Exit without Save**, or **Edit** existing data. Select your desired option and press Enter.

**NOTE:**

To print, you must be paired to a Wireless Bluetooth Printer (see [Section 8.3.3](#)). To send data to TPMS Desktop, you must be paired to a PC (see [Section 8.3.2](#)).

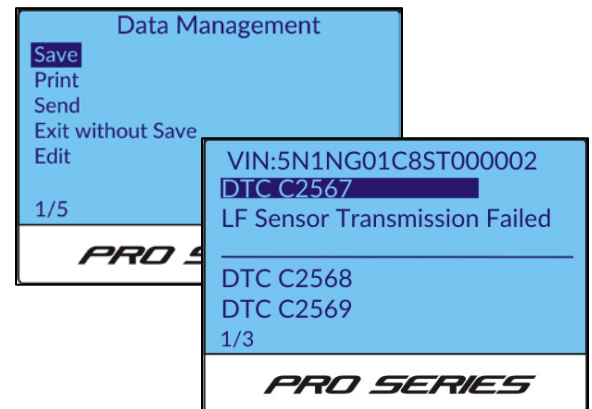

### 3.6 TBYT Toolkit

While on the Operations screen of the **Test Before You Touch** function, you can access the **TBYT Toolkit** by using the arrow keys to navigate to the wrench icon, then pressing Enter to open the menu.

#### OBD (300PROC and 400PRO Only)

The OBD function will pull existing OBDII data (e.g. VIN, sensor IDs, DTCs) from the vehicle and display it. Connect the tool to the vehicle via the OBDII cable, select **OBD** from the TBYT Toolkit menu, and press the Enter key to start the search.

#### Sensor Search

The Sensor Search function can be used to identify unknown sensors. Place the sensor at the top of the tool (or position the tool accordingly if the sensor is installed in the wheel – see [Section 2.3](#)) and select **Sensor Search** from the TBYT Toolkit menu, then press the Enter key to start the search. The tool will display any results found.

**NOTE:**

Reprogrammable sensors that have not yet been programmed will not be detected by this search function.

#### RKE Test

RKE Test is also available through the **Home > Toolkit** menu; see [Section 7.2](#) for details.

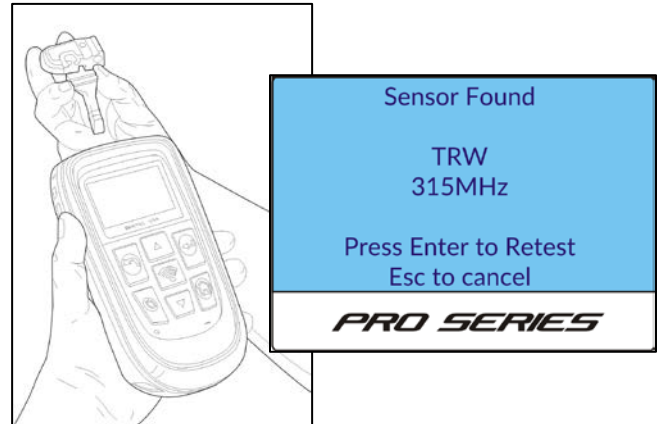
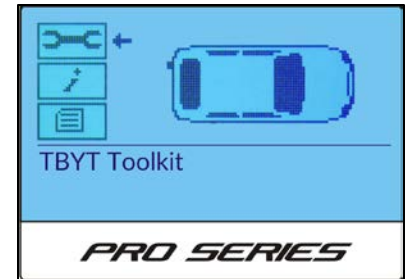

## 4.0 Program Sensor

Bartec PRO Series tools offer a unique feature: the ability to program various aftermarket sensors. Select **Program Sensor** from the Home menu and follow all on-screen instructions relating to sensor programming.

**Program Sensor** can also be accessed from the Relearn Toolkit (see [Section 5.6](#)).

### 4.1 Procedure

Bartec recommends programming sensors before fitting them to the wheel. Ensure there are no other sensors within a 10-foot range during sensor programming to prevent RF interference.

To program a sensor, select the MMY of the vehicle.

**Universal Sensors:** Select the type of sensor being programmed. Only the listed sensors are supported for that vehicle.

**NOTE:**

If the sensor type selected does not require programming, the tool will prompt accordingly.

**ID Option: Create ID** creates a unique ID for each sensor and is used for the majority of sensor programming. **Copy ID** should only be used when programming different tire sets for the same vehicle (e.g. summer/winter tires).

**Wheel Position:** Select the wheel position for that sensor.

Follow the on-tool prompts to complete the programming.

### 4.2 Contact Sensors

“Contact” or “CUB-style” aftermarket replacement sensors are fully programmable, but require a direct connection to a programming tool via contact leads (i.e. no wireless programming). Because of this design, these sensors can only be programmed outside of the wheel.



All Bartec PRO Series tools support programming contact sensors using the CUB Programming Fixture accessory (see [Section 10.3: Accessories and Replacement Parts](#)).

Follow the instructions on the CUB Programming Fixture’s included Quick Start Guide and the on-tool prompts to complete sensor programming.

## 5.0 Relearn

A TPMS relearn is the process in which TPMS sensor IDs are stored or written to the ECM of the vehicle. There are five categories of TPMS relearns:

- Stationary
- Auto (Drive)
- OBDII Connect
- OBDII Assisted
- Indirect (Vehicles have no sensors)

Your PRO Series tool will display the relearn process right on the screen, and will also list the Tire Industry Association (TIA) Relearn Process Reference number for cross-reference to the TIA TPMS Relearn Chart.

Bartec recommends performing a TPMS relearn any time a vehicles' tires are removed.

When a vehicle is selected on the PRO Series tool by MMY, the relearn procedure can be viewed at any time by using the arrow keys to navigate to the Information icon, pressing Enter, and then selecting **View Relearn Procedure**.

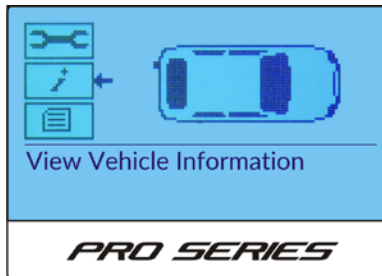

## 5.1 Stationary Relearns

Stationary Relearns use the vehicle's on-board TPMS system to listen for transmissions from TPMS sensors while the vehicle is in "Learn Mode". This is usually achieved through a series of actions performed on the vehicle to place it into this mode. Once the vehicle is in Learn Mode, use your PRO Series tool to activate the sensors. The vehicle will listen for the sensor IDs and assign them to the correct wheel positions on the vehicle.

## 5.2 Active (Drive) Relearns

Some vehicles can relearn by being driven. Refer to the tool's on-screen relearn procedures for details on the driving time and distance requirements for specific vehicles.

## 5.3 OBDII Relearns (300PROC and 400PRO Only)

An OBDII relearn is either a vehicle that requires the OBDII connection to complete the registration of new TPMS sensor IDs to the vehicle, or is optional coverage for Stationary or Auto Relearn vehicles. Connection to a vehicle allows the PRO Series tool to directly program the vehicle's ECM with TPMS sensor IDs.

**NOTE:**

Not all vehicles support vehicle communications modes.

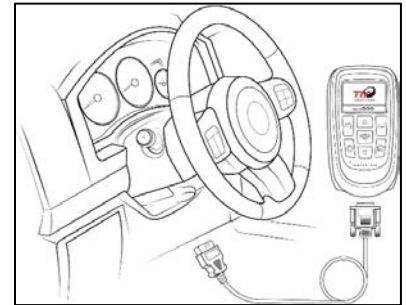

1. Select **Relearn** from the Home menu.
2. Select the Make, Model, and Year of the vehicle you are working on.

**NOTE:**

Use the 10<sup>th</sup> digit of the VIN to verify the Model Year and ensure accuracy (see [Appendix B](#) for details).

**NOTE:**

If the Year you are working on is not an option, ensure that your tool's software is up-to-date (see [Section 1.9](#)). Contact Bartec Technical Support (see [Section 11.0](#)) to verify whether a work-around exists.

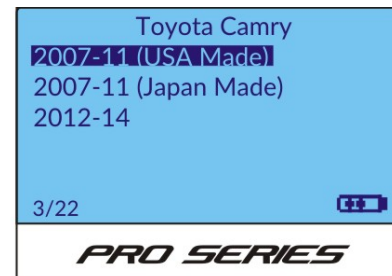
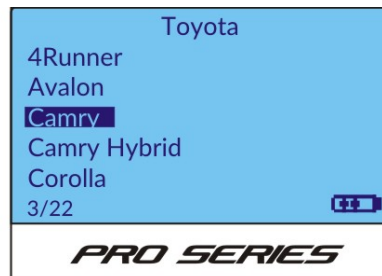

### 5.3 OBDII Relearns (300PROC and 400PRO Only) (Continued – 2)

- Follow the on-tool prompts to complete the relearn process.

**NOTE:**

It is important to read the instructions IN FULL before proceeding, as some vehicles require additional steps following the OBDII connection to complete the relearn (e.g. many Honda vehicles using the OBDII relearn method require driving for a set time/distance to complete the process).

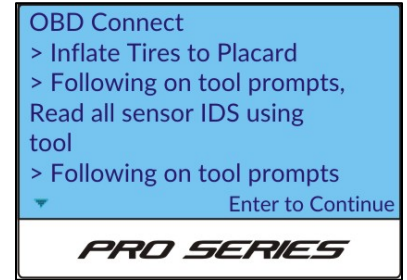

- On the Operations screen, the tool will default to the Left Front wheel position and prompt with **Press Test to Activate Left Front**. Position the tool accordingly (see [Section 2.3](#) for proper tool positioning) and press the Test key.

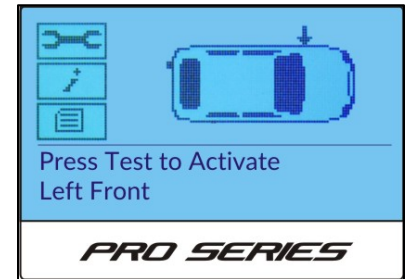

The tool will send the LF signal necessary to activate the sensors for the selected MMY and listen for the correct UHF output from the sensor. Keep the tool in position until the progress bar has completed and the tool indicates the results next to that tire position (see [Section 2.3.4](#) for possible responses).

- Continue with the Right Front, Right Rear, and Left Rear as the tool prompts you. The tool should indicate a successful read with “All Sensors OK”.



**NOTE:**

If any sensors give an undesired response (see [Section 2.3.4](#) for possible responses), the relearn will not be successful. Correct any sensor issues and start the relearn process over again.



### 5.3 OBDII Relearns (300PROC and 400PRO Only) (Continued – 3)

6. Connect the OBDII cable to the tool and vehicle, then turn the key to the key on/engine off position.

**NOTE:**

If the vehicle has a push-button start, cycle the button until all the accessories (e.g. the radio) are functional.

Once connected, press the Enter key to begin writing the sensor IDS directly to the control module.

The tool will indicate accordingly when the process is completed. Disconnect the OBDII cable from the vehicle, then follow any additional instruction prompts on the tool to complete the relearn process. If no additional steps are required, the relearn process is complete.



7. The next menu allows the option to **Save** or **Print** data, **Send** data to TPMS Desktop, **Exit without Save**, or **Edit** existing data. Select your desired option and press Enter.

**NOTE:**

To print, you must be paired to a Wireless Bluetooth Printer (see [Section 8.3.3](#)). To send data to TPMS Desktop, you must be paired to a PC (see [Section 8.3.2](#)).

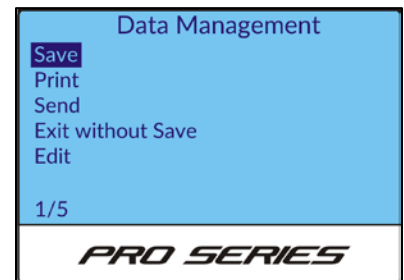

### 5.4 OBDII Assisted Relearns (Mitsubishi Only)

This relearn process applies specifically to the Mitsubishi Lancer, Outlander, Mirage, and RVR vehicles. This process requires your 300PROC or 400PRO tool to remain connected to the OBDII port during the relearn process while you activate the sensors (by either reducing the air pressure in the tire, or activating the sensors with a second tool). This process also requires a specific OBDII Adapter Kit (Bartec Part Number: **WRTOBD002**).

For more details, refer to Bartec USA's [Technical Service Bulletin RP-201-014](#).

## 5.5 Indirect Systems

There are no pressure sensors used in indirect TPMS systems; as a rule, most indirect systems have a Reset button for recalibrating the system. After selecting the MMY of the vehicle, refer to the on-tool prompts for completing the relearn process.

## 5.6 Relearn Toolkit

While on the Operations screen of the **Relearn** function, you can access the **Relearn Toolkit** by using the arrow keys to navigate to the wrench icon, then pressing Enter to open the menu.

### Program Sensor

[See Section 4.0](#) for sensor programming procedures.

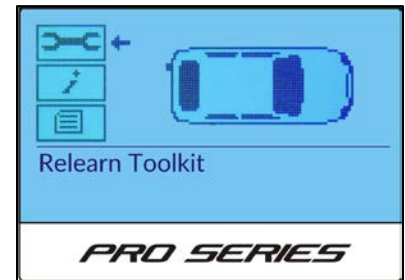

### OBD (300PROC and 400PRO Only)

The OBD function will pull existing OBDII data (e.g. VIN, sensor IDs, DTCs) from the vehicle and display it. Connect the tool to the vehicle via the OBDII cable, select **OBD** from the TBYT Toolkit menu, and press the Enter key to start the search.

### Sensor Search

The Sensor Search function can be used to identify unknown sensors. Place the sensor at the top of the tool (or position the tool accordingly if the sensor is installed in the wheel – see [Section 2.3](#)) and select **Sensor Search** from the TBYT Toolkit menu, then press the Enter key to start the search. The tool will display any results found.

#### NOTE:

Reprogrammable sensors that have not yet been programmed will not be detected by this search function.

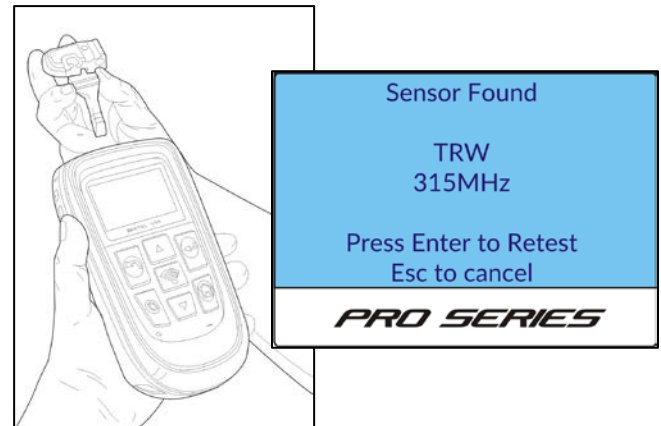

### RKE Test

RKE Test is also available through the **Home > Toolkit** menu; see [Section 7.2](#) for details.

## 6.0 Vehicle Data

This menu selection will give you the option to upload stored data to a PC, or review data currently stored on the tool.

### 6.1 Upload Stored Data

When your tool is paired to a PC via Bluetooth, you can select this option to send audit data wirelessly to your PC for use with the TPMS Desktop application. See [Section 8.3.2](#) for more information on pairing, and [Section 9.0](#) for details on TPMS Desktop.

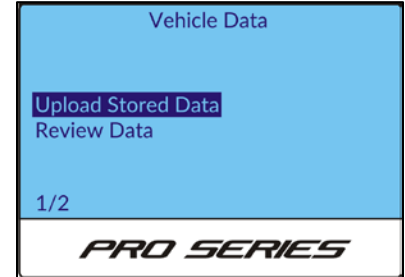

### 6.2 Review Data

When selected, this option displays all the TPMS data available from the TPMS type being read (e.g. sensor IDs, battery state, DTCs, pressure). Not all TPM systems provide the same data sets.

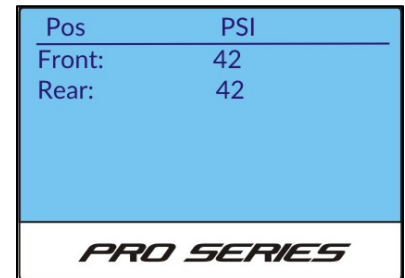
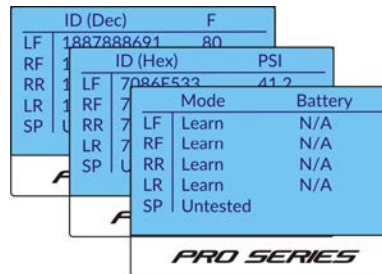
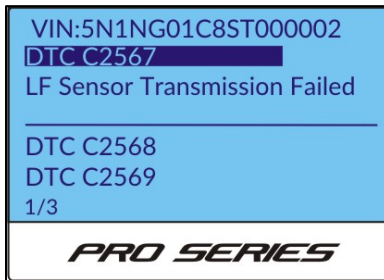

## 7.0 Toolkit

The Toolkit menu contains additional miscellaneous testing features and (in the case of the 400PRO) the Placard Change function.

## 7.1 Placard Change (400PRO Only)

Vehicles with TPMS are required to alert the driver to an existing LOW PRESSURE condition at or below 25% of the placard value. Bartec's 400PRO Series tool can now adjust the placard pressure as required for certain alternate wheel and tire combinations. By using the OEM Load Index charts and following proper plus sizing practices, the vehicle's TPMS can be updated with the new placard pressure.

**NOTE:**

To determine the new placard values, use the Tire and Rim Load Index (or equivalent) chart as supplied by the tire manufacturer.



**For safety reasons, NEVER replace a tire with one that is a lower load rating than the OE!**

### To Perform a Placard Change:

1. From the Home menu on the tool, select **Toolkit**.
2. Select **Placard Change**.
3. Read the on-tool notice, then press Enter to continue.
4. Connect the tool to the vehicle with the OBDII cable, turn the vehicle's ignition to the key on/engine off position, and press Enter on the tool to read the VIN.
5. Once the tool reads the VIN, press Enter to continue.
6. Select the Make, Model, Year, and Load Range of the vehicle, then press Enter to confirm and continue.
7. Select the new Front Axle Pressure and press Enter.
8. Select the new Rear Axle Pressure and press Enter.
9. The tool will indicate each step it completes as it writes the new placard data to the system.
10. Verify the changes listed on the tool are correct, and press Enter.

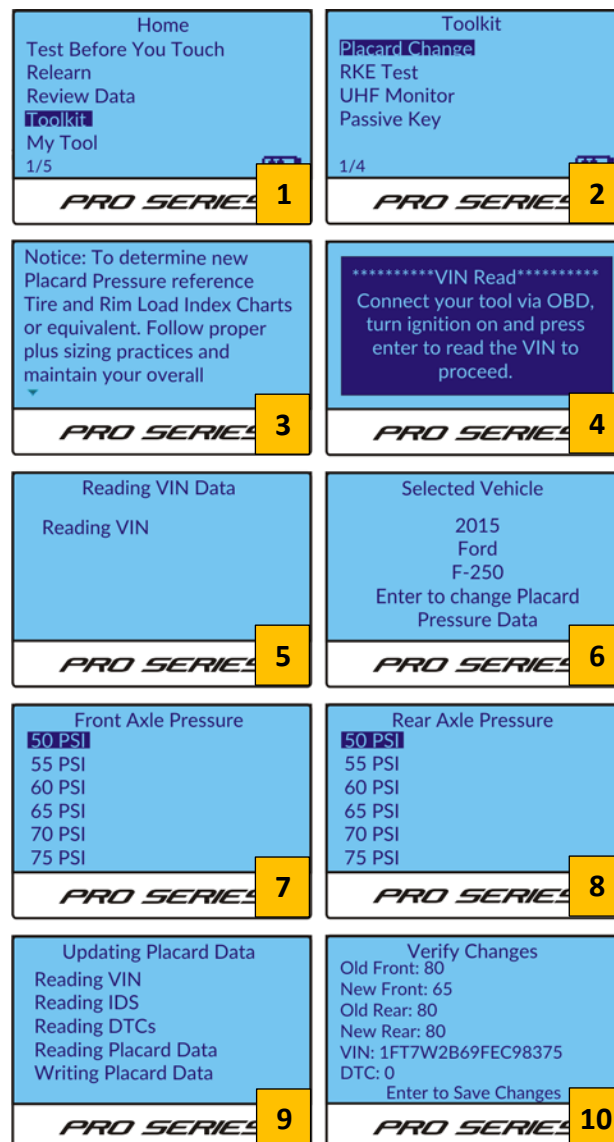

## 7.1 Placard Change (400PRO Only) (Continued – 2)

Once a placard change is completed on the tool:

1. Adjust the air pressure in all tires according to the new placard values.
2. Place a new placard sticker on the vehicle's B-pillar with the updated pressure, tire size, and load information as required.

**NOTE:**

Attach the supplemental placard label as close to the OEM placard label as possible. DO NOT cover the OEM placard label.



## 7.2 RKE Test

Since certain relearn procedures require using a key fob, the RKE Test function can be used to ensure that a fob is transmitting properly.

Select **RKE Test** from the Toolkit menu, then press the Enter key. To start testing, simply touch the key fob to the top of the tool and press any button on the fob. The tool will display any signal received from the fob in MHz.

**RKE Test** can also be accessed from the **TBYT Toolkit** (see [Section 3.6](#)) and the **Relearn Toolkit** (see [Section 5.6](#)).

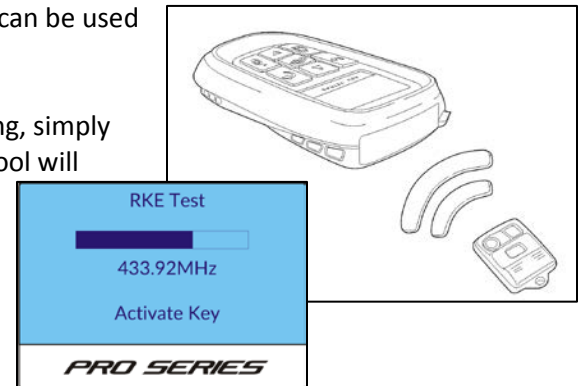

## 7.3 UHF Monitor

The UHF Monitor feature tests for nearby UHF signals. If you suspect your tool is not scanning properly due to signal interference (e.g. works fine in one building, but fails in another), simply select UHF Monitor while in the suspected problem area. If the tool picks up any nearby signals, it will display accordingly on the readout.

## 7.4 Passive Key (400PRO Only)

Passive Key or Push Button Start vehicles generally send out a LF signal to activate the key fob. Bartec has incorporated the ability to detect those LF signals, and display that information on the screen of your tool.

This feature is a basic pass/fail test, and assists the technician in determining if there is a problem with the transmission from the key fob or vehicle. Results may vary depending on the MMY you are testing.

After selecting the Passive Key feature, hold the tool against the keyless entry pad on the vehicle door, or touch the key fob to the top of the tool and press any button on the fob. The tool will display any signals received.

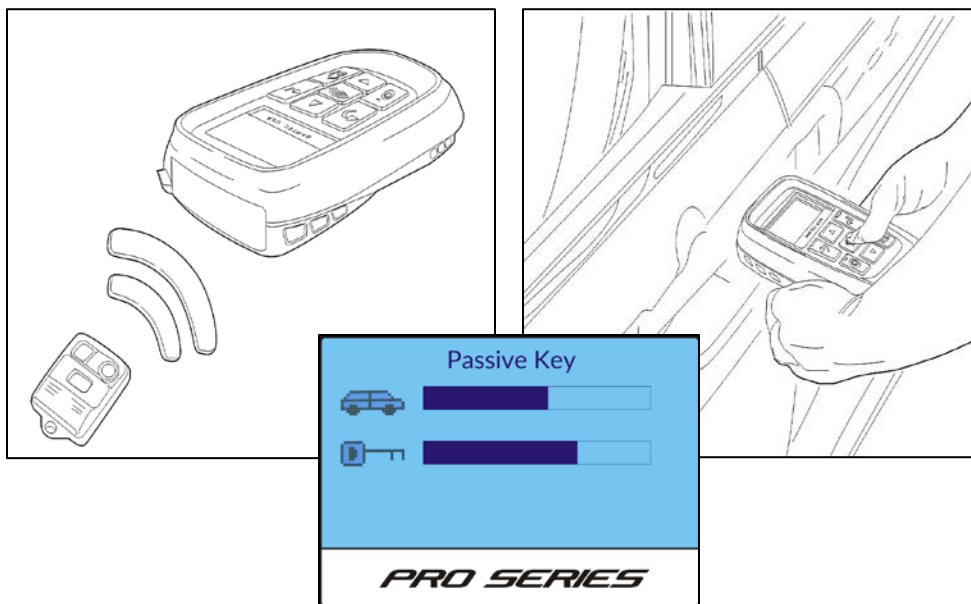

## 7.5 Unlock REDI 7002A

If a REDI 7002A sensor has already been programmed and needs to be fitted to a different vehicle, it must first be “unlocked”. Use this feature and follow the on-tool prompts to unlock the sensor.

## 8.0 My Tool

The **My Tool** menu allows the user to configure and manage their PRO Series TPMS tool. Review this section to optimize the tool for your personal use.



## 8.1 Settings

**TPM ID:** Select to display sensor IDs in DECIMAL or HEXIDECIMAL format.

**Pressure:** Change how pressure is displayed on the tool screen. Choose between PSI or Bar.

**Temperature:** Select units between Celsius or Fahrenheit.

**Display Contrast:** Adjust tool display contrast.

**Lang.:** Select Language for tool. Select English, Spanish or French.

**Date/Time:** The PRO Series tool has an internal clock that allows the data storage to be date/time stamped based on when the action took place. Using this setting allows the user to adjust the date/time if necessary.

**NOTE:**

Upon initial start-up or complete power loss, the tool will prompt the user through setting the date/time as part of the tool setup.

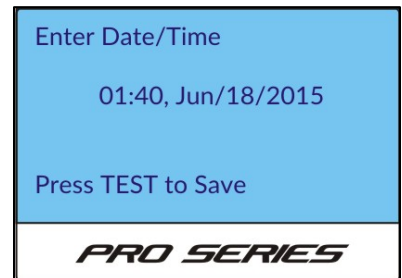

**Restore Defaults:** Resets all settings to factory values. The user will be prompted to confirm upon selecting this feature.

## 8.2 WiFi (400PRO Only)

**NOTE:**

If you have a private, non-broadcasting WiFi network, you must use the **Tool Wireless Config** application ([Section 1.8](#)).

**Using the tool to configure Wi-Fi (no PC required):**

1. From the **Home** menu of your PRO Series tool, navigate to **My Tool > WiFi and Bluetooth > Wi-Fi**.
2. Ensure that **WiFi** is set to **Enabled**, then select **Join Network**.
3. The tool will scan for nearby broadcasting networks.
4. Use the arrow keys to highlight your desired network from the list of available WLAN Networks and press Enter to select.
5. Enter your passphrase by using the Up and Down arrow keys to select each character (hold a key down for faster scrolling). Use the Enter key to move to the next character, and press the Test key to save and connect.
6. The tool will show connection status and prompt upon a successful network connection. Once prompted, press the Enter key to check for updates, or the Esc key to cancel.

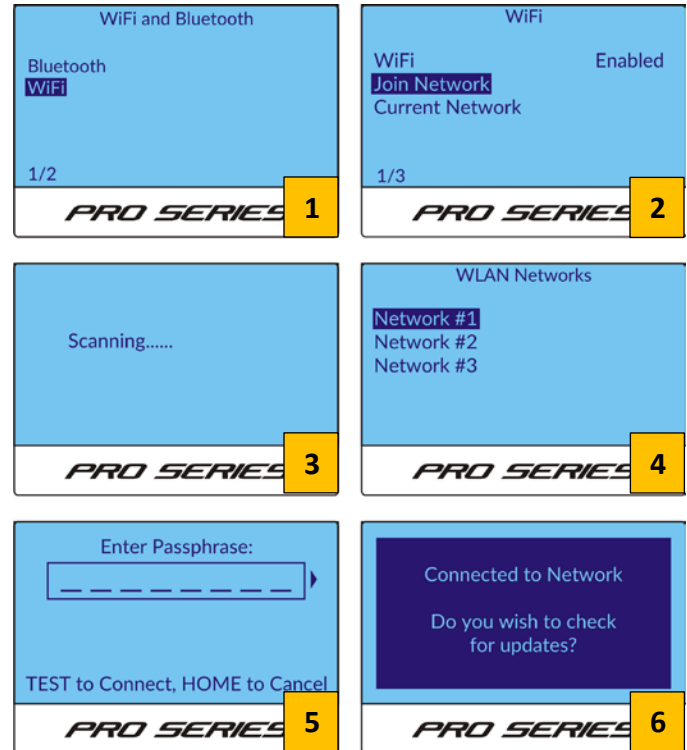

## 8.3 Bluetooth

All PRO Series tools can be paired to a PC with Bluetooth capabilities, allowing you to send audit data wirelessly to the TPMS Desktop application (see [Section 9.0](#) for details on TPMS Desktop). You can also pair your tool to the Bartec Wireless Bluetooth Printer accessory (sold separately – see [Section 10.3](#) for part number) for quick and easy printing of audit data.

For Bluetooth functions, select **WiFi and Bluetooth > Bluetooth** from the **My Tool** menu.

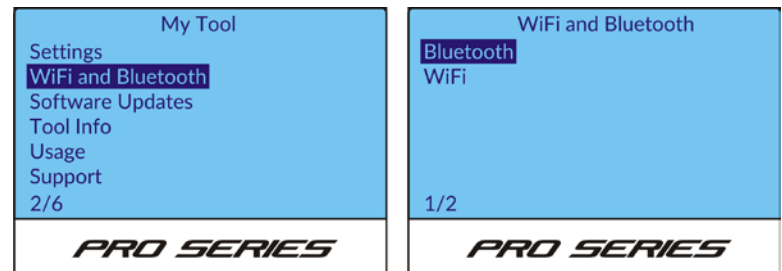

### 8.3.1 Enabling Bluetooth

To enable or disable Bluetooth on your tool, select **Bluetooth** and press Enter, then choose **Enabled** or **Disabled** accordingly and press Enter to save.

**NOTE:**

Bluetooth must be **Enabled** on your tool in order to pair to a PC or Bluetooth Printer. The **Bluetooth** menu will not display additional pairing options until Bluetooth is set to **Enabled**.

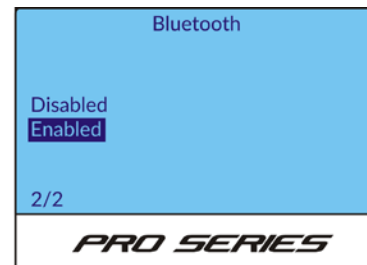
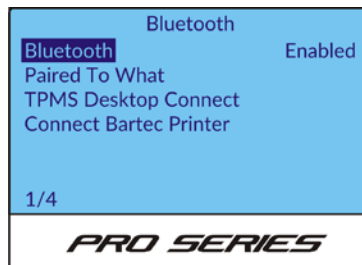

### 8.3.2 Pair to a PC

To pair the PRO Series tool to a PC with TPMS Desktop:

1. Ensure the PC you are pairing to has Bluetooth capabilities (see [Section 1.7](#) for details).
2. Open TPMS Desktop on your PC and click **Settings**. Click to expand the **Bluetooth** heading, and ensure the boxes for **Connectable** and **Discoverable** are checked (if they are blank, click to check them off).

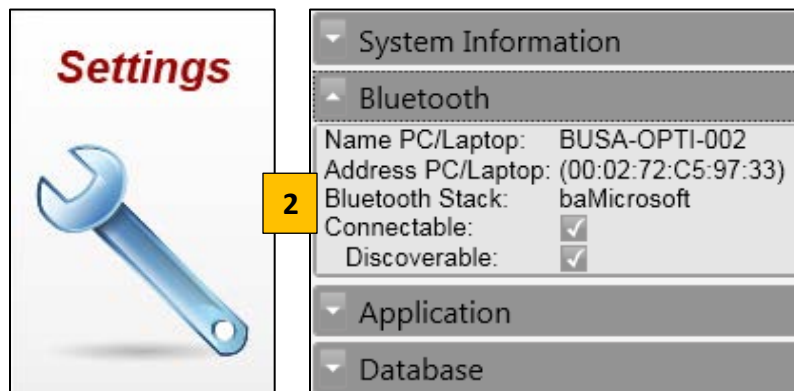

**NOTE:**

Keep the TPMS Desktop application open throughout the rest of this process.

### 8.3.2 Pair to a PC (Continued – 2)

3. On the tool's **Bluetooth** menu, select **TPMS Desktop Connect** and press Enter.

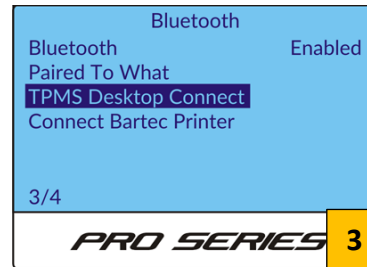

4. The tool will scan for available devices.

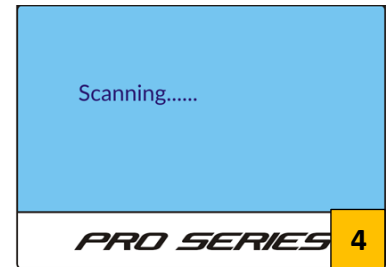

5. Select your PC's name from the list provided and press Enter.

**NOTE:**

If you are unsure of your PC Name, it is also displayed in TPMS Desktop under the **Bluetooth** heading.

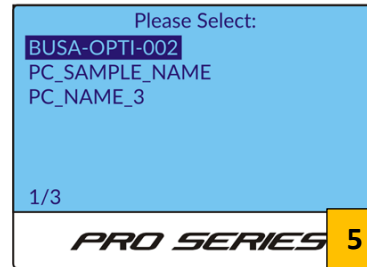

6. The tool will attempt to pair while showing "Connecting..." on the screen.



7. Upon successful pairing, the tool will show a "Bluetooth Connected – Data Sent" prompt, then return to the **Bluetooth** menu. TPMS Desktop will also prompt upon successful Bluetooth pairing.

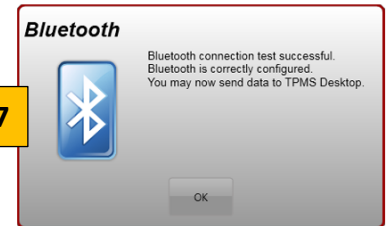
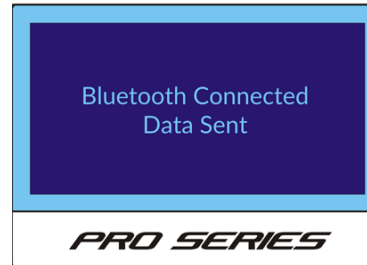

### 8.3.3 Pair to a Bluetooth Printer

To pair the PRO Series tool to a Bluetooth Wireless Printer:

1. Turn the Bluetooth Printer on with the Power button.
2. On the tool, under the **Bluetooth** menu, select **Connect Bartec Printer** and press **Enter**.
3. The tool will scan for available devices.
4. Select your printer name (Bartec Bluetooth printers always begin with “BARTEC-PR-”), then press Enter.
5. The tool will attempt to pair while showing “Connecting...” on the screen.
6. Upon successful pairing, the tool will show a “Bluetooth Connected – Data Sent” prompt, then return to the **Bluetooth** menu.

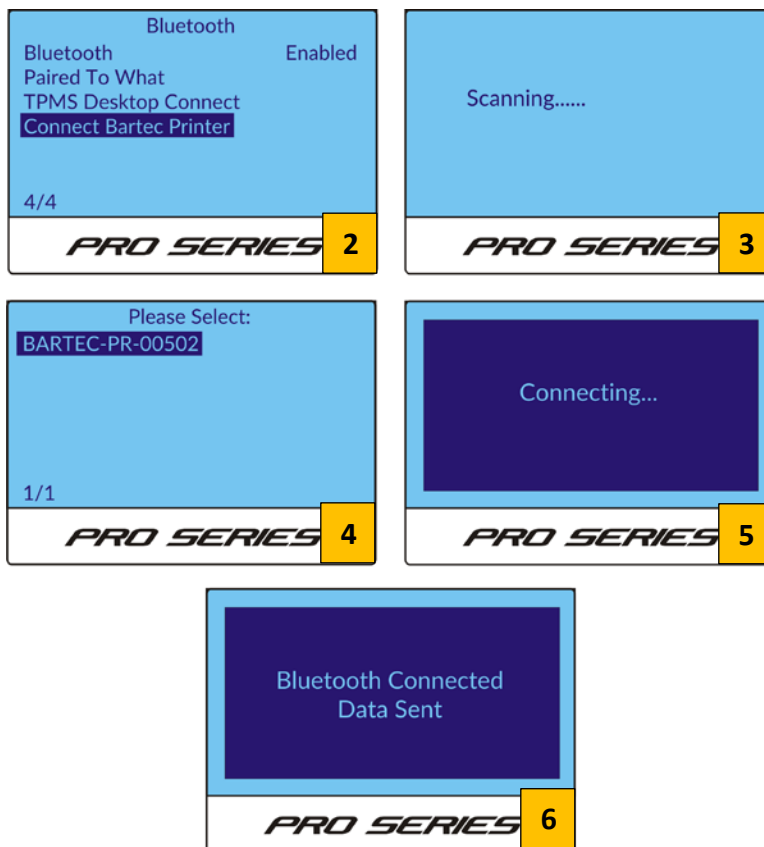

### 8.3.4 View Paired Devices

If you need to determine which PC or Bluetooth Printer your tool is paired to, simply select **Paired To What** from the Bluetooth menu to display the paired device names.

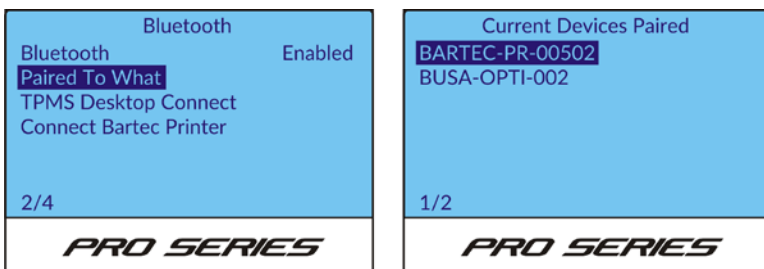

## 8.4 Software Updates (400PRO Only)

### 8.4.1 WiFi Updates

If your 400PRO tool has been connected to a WiFi network (see [Section 1.8](#)), you can use the **Schedule Check** option to configure the 400PRO to automatically check for updates **Daily**, **Weekly**, or **Monthly** via WiFi when powered on (select **Off** if you do not wish to auto-update). If an update is detected, the 400PRO will prompt the user at boot-up.

You can also manually check for updates by selecting the **Check Now** menu option.

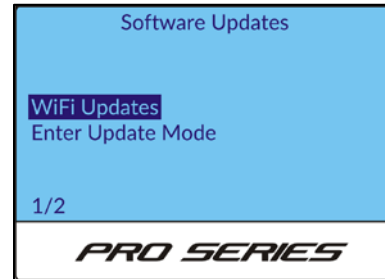
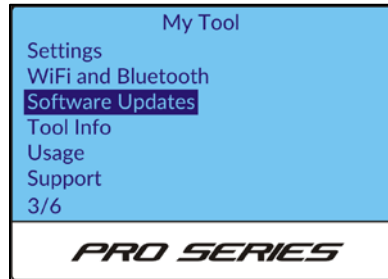

**NOTE:**

Because WiFi network speeds can vary, some users with slower WiFi prefer to leave the **Schedule Check** option set to **Off** so as not to slow down the initial boot-up of the tool.

### 8.4.2 Enter Update Mode

Press Enter on this selection to put your tool into Update Mode (see [Section 1.9](#) for details on updating).

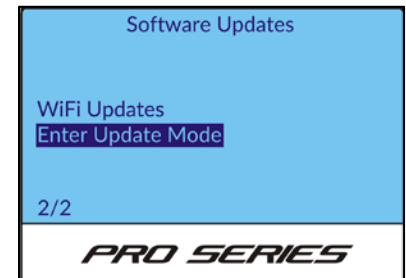

## 8.5 Tool Info

Select this menu option to display tool information (e.g. serial number, current software version).



## 8.6 Enter Update Mode (300PRO Only)

Press Enter on this selection to put your tool into Update Mode (see [Section 1.9](#) for details on updating).



## 8.7 Usage

Select this menu option to display tool statistics, including the number of:

- Power Cycles
- Sensor Activations
- OBD Relearns

These tool statistics are static and cannot be reset by the end user.

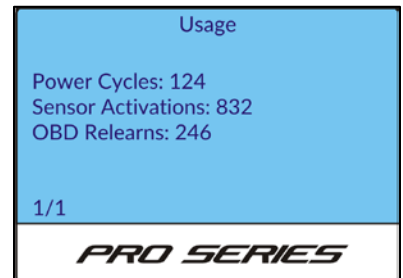

## 8.8 Support

Select this menu option to display contact information for Bartec USA Technical Support ([see Section 11.0](#)).

## 9.0 TPMS Desktop

Bartec created the TPMS Desktop software to let you easily manage and update your Bartec TPMS tools, and to enhance your ability to provide complete TPMS diagnostics and service to your customers.

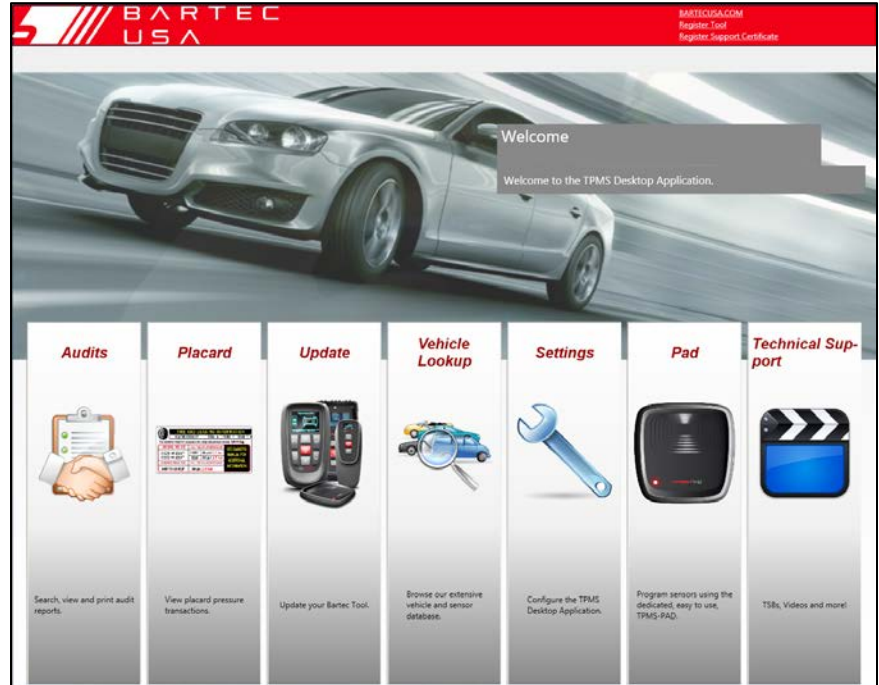

## 9.1 TPMS Desktop Updates

If your PC has an internet connection, TPMS Desktop may periodically prompt for updates when first launched.

Click **OK** on the update prompt, and the update will download and install automatically. Follow any additional on-screen instructions.

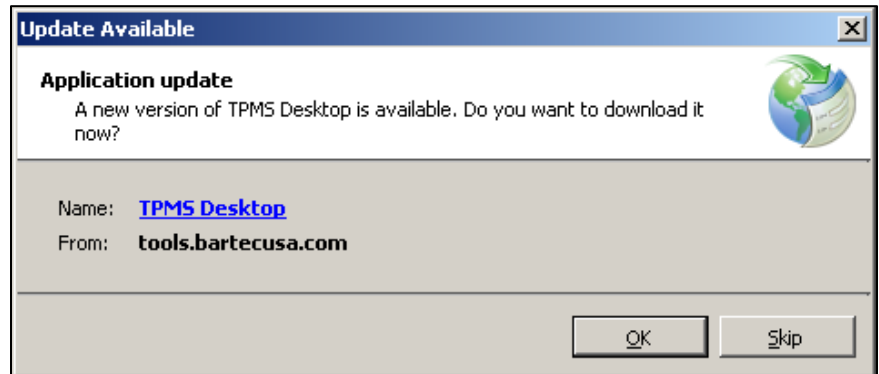

## 9.2 Audits

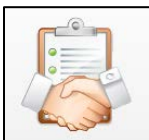

Search, view, and print your TPMS tool's Test Before You Touch and Relearn audit data after sending it wirelessly to TPMS Desktop. Use the Filters options in the left menu to sort by Date and/or Make/Model/Year, or search by vehicle license.



**Print:** Select between Customer and Detailed formats to print an individual audit report.



**Edit:** Edit or add data to an individual report (e.g. vehicle license, customer name and contact information).



**Link:** Use to link multiple audit files for the same vehicle.

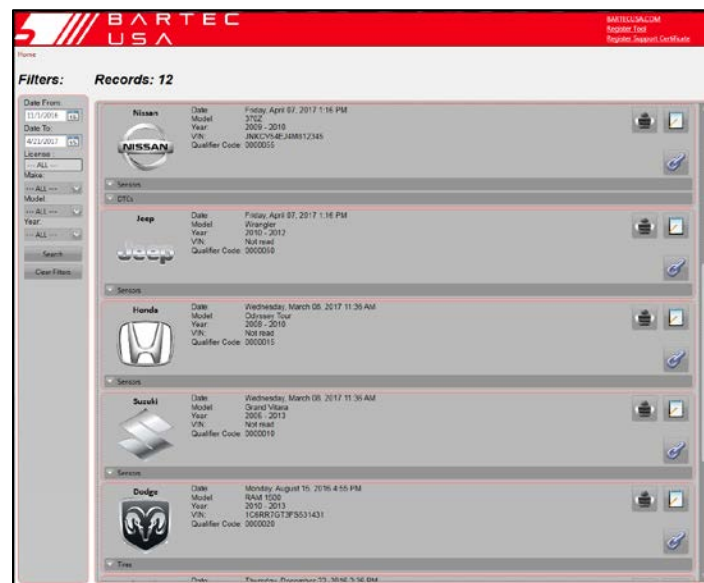

## 9.3 Placard (400PRO Only)



Search, view, and print your 400PRO tool's Placard audit data after sending it wirelessly to TPMS Desktop. Use the Filters options in the left menu to sort by Date and/or Make/Model/Year, or search by vehicle license.



**Print:** Select between Customer and Detailed formats to print an individual audit report.



**Edit:** Edit or add data to an individual report (e.g. vehicle license, customer name and contact information).



**Link:** Use to link multiple audit files for the same vehicle.

## 9.4 Updates



**Updates** provides access to tool management and software updates for your TPMS tools, and automatically retrieves available update files as needed.

With the **Updates** screen selected, connect your PRO Series tool to the PC using the provided mini USB cable. Under **Connected Tools**, your tool's information will populate. If the **Update** button is highlighted, click it and the TPMS desktop application will walk you through the update process.

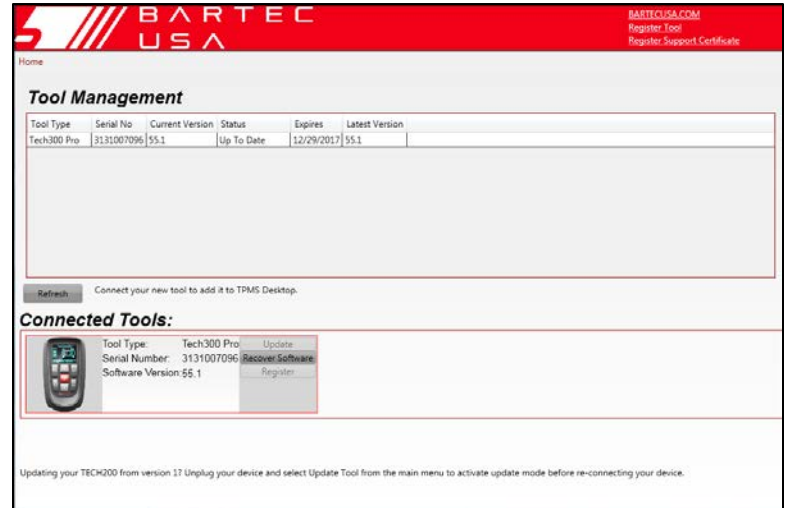

## 9.5 Vehicle Lookup



Select a Make/Model/Year to view the information on vehicle TPMS type, supported sensors, and relearn procedures. There is a quick link to the Bartec TPMS HUB for a full description of TPMS data, procedures and part lookup data.

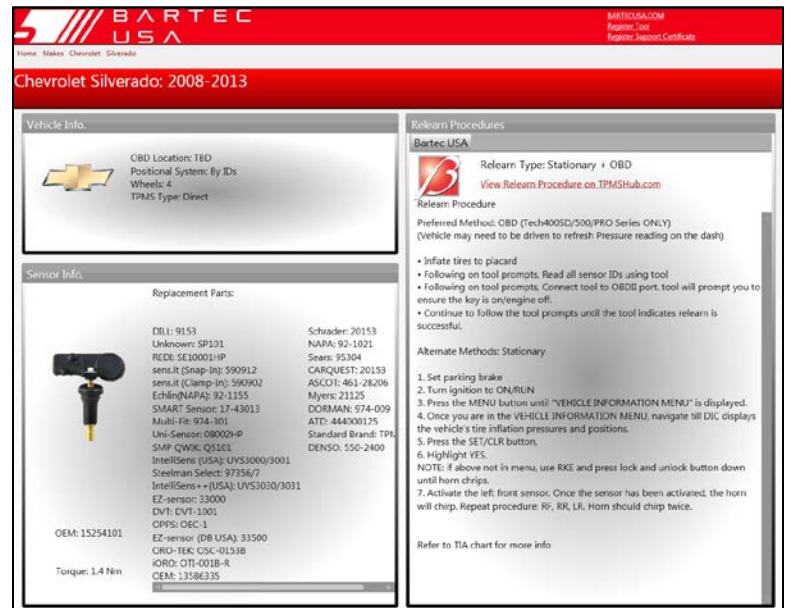

## 9.6 Settings



View and configure the settings for TPMS Desktop, including Bluetooth connections. Access log files when requested by Technical Support.

## 9.7 PAD



Launches the PAD application, used to program aftermarket replacement sensors using the Bartec Programming Accessory Device (PAD) tool, sold separately (see [Section 10.3](#)).

## 9.8 Technical Support



Links to Bartec's Online Training, including Technical Service Bulletins, User Guides, training videos, and more.

## 10.0 Tool Service

Your PRO Series tool has been designed especially for the rugged automotive shop environment. When properly cared for and maintained, it will provide years of service. However, accidents happen, and when they do, Bartec stands at the ready to deliver excellent support and service to get you up and running again.

### 10.1 Proper Care and Cleaning

Like all electronic tools, your PRO Series tool should always be kept in a safe place away from liquids and damaging chemicals. From time to time, cleaning of the enclosure and the screen will be required. To clean the tool, use a mild, non-abrasive spray cleanser applied to a soft cloth, and wipe the external surfaces of the tool.



**Never apply chemicals, cleansers, or liquids directly to the tool.**

## 10.2 Service

The PRO Series tool is not field serviceable. If damage occurs, or the tool does not power on, follow these steps to get you back up and running again:



1. Contact our Technical Support team with your concerns (see [Section 11.0](#)). Please ensure your tool is registered and have the serial number ready.
2. If our Technical Support team cannot correct your issues in the field, they will begin the process for a Return Material Authorization (RMA) to have your tool sent in for service.
3. Our Technical Support team will pass your information along to our Repair department, who will assist you with the details on processing your return. Information you should receive includes:
  - Your RMA #
  - Ship-to address of our repair facility
  - Confirmation of your return shipping address





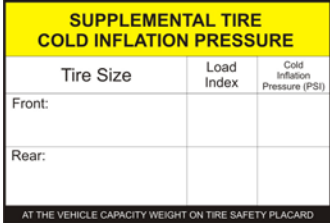

**Do not attempt to open your Bartec tool, as this will void your warranty!**

### 10.3 Accessories and Replacement Parts

Item	Description	Bartec Part Number
	<a href="#">OB2 Upgrade Kit for 300PRO</a>	WRT300PROUPG
	Wall Mount Cradle	WRTPROWMC
	Wireless Bluetooth Printer	WRTPROWMP

Item	Description	Bartec Part Number
	<p><a href="#">CUB Programming Fixture</a></p>	<p>WRT500CPF002</p>
	<p>Supplemental <a href="#">Placard</a> Labels</p>	<p>Roll of 25: WRTPLACARD25</p> <p>Roll of 100: WRTPLACARD100</p>
	<p><a href="#">TIA Relearn Chart</a></p>	<p>WRTTIA16</p>
	<p>Mini USB Cable</p>	<p>WRT300USB</p>

Item	Description	Bartec Part Number
	1 Piece OBDII Cable	WRT400OBDC
	Wall Mount Power Supply	WRT400PWS
	Inductive Charging Pad w/ Power Supply	WRT500PAD
	<a href="#">TPMS Magnet</a>	WRTMAGNET
	Bluetooth Dongle	WRTBTDONGLE

## 11.0 Technical Support

To speak with our Technical Support team, please call our toll-free number:

**(866) 407-8767**

Hours of operation: 8am-8pm EST, Monday-Friday

Or contact us by email: [help@bartecusa.com](mailto:help@bartecusa.com)

Visit our website at [www.bartecusa.com](http://www.bartecusa.com) for a complete directory.

For efficient and accurate service, please have the following information ready when contacting us:

- **Tool Serial Number:** This allows your call information to be added to our database for future reference.
- **Ensure your tool is registered:** A tool registered with Bartec USA gives you access to technical information which may assist you with your current issue (see [Section 1.6](#) for more information on registration).
- **Ensure your tool is up-to-date:** Having an updated tool ensures you have all the latest information and features (see [Section 1.9](#) for information on software updates).
- **Sensor Part Number:** If you have installed one or more sensors to a vehicle, please have the part number ready in case Technical Support needs to reference sensor-specific information.
- **Make, Model, and Year of the vehicle:** Technical Support will need this information to reference any vehicle-specific issues.
- **Status of the TPMS light on the vehicle:** Is the TPMS light solid or flashing when the vehicle is first keyed on?
- **Have the vehicle in question in-house:** This helps our Technical Support team to walk you through resolving the situation.

## 12.0 Appendices

### A - GLOSSARY

Audit Data is all the sensor and OBD data stored on the tool.

Bar units are commonly used in many Western European countries as a metric unit of pressure. 1 bar equals 100 kPa, or approximately 14.5038 psi.

Bluetooth is a wireless technology standard for exchanging data over short distances from fixed and mobile devices.

Direct System is a TPMS that has RF sensors in the wheels.

Hi-Line or High-Line is a TPMS type that has wheel-mounted receivers, which can force periodic transmissions from each wheel sensor to keep a continuously updated pressure status. Vehicles using hi-line TPMS usually have a graphic display in the dash.

Indirect System are the systems that do not have air pressure sensors inside the tires. Instead, they detect a low tire by comparing relative wheel speeds via the Anti-Lock Brake System (ABS) wheel speed sensors.

Inductive Charging or Qi (also known as "wireless charging") uses an [electromagnetic field](#) to transfer energy between two objects. This is usually done with a charging station. Energy is sent through an [inductive coupling](#) to an electrical device, which can then use that energy to charge batteries or run the device.

kPa (or kilopascal) is a metric unit of pressure measurement widely used throughout the world. 1 kPa equals approximately 0.145038 psi.

LF (Low Frequency) is the [ITU](#) designation for radio frequencies in the range of 30 kHz–300 kHz, usually 125 kHz with respect to TPMS technology.

Lo-Line or Low-Line is a TPMS type that uses a passive receiver to listen for sensor transmissions. Vehicles using low-line TPMS usually have a simpler dash display (e.g. a single on/off/flashing TPMS warning light).

Mini USB (Universal Serial Bus) is a smaller, 5-pin cable connector that is used by various handheld electronic devices. It is often used for both [USB](#) data connectivity as well as charging.

On-board diagnostics (OBD) is an automotive term referring to a vehicle's self-diagnostic and reporting capability. Modern OBD implementations use a standardized digital communications port to provide real-time data in addition to a standardized series of [diagnostic trouble codes](#) (DTCs), which allow one to rapidly identify and remedy malfunctions within the vehicle.

## A – GLOSSARY (Continued – 2)

OBDII is a newer system standard introduced by the [SAE](#) in the mid-'90s. All cars built since January 1<sup>st</sup>, 1996 have OBDII systems.

Passive Key Technology (also referred to as I-Key) – Key systems on vehicles that operate wirelessly and use a push button start.

psi (pound per square inch or, more accurately, pound-force per square inch) is a unit of pressure based on avoirdupois units, commonly used in the United States.

Relearn refers to the process of registering the sensor IDs to the vehicle's ECM.

RKE ([Remote Keyless Entry](#)) is an electronic lock that controls access to a vehicle without using a traditional mechanical key.

Secure Digital (SD) is a [non-volatile](#) memory card format developed by the [SD Card Association](#) for use in portable devices.

TPMS (Tire Pressure Monitoring System) is an electronic system designed to monitor the air pressure inside the tires on various types of vehicles.

UHF (Ultra High Frequency) is the [ITU](#) designation for radio frequencies in the range between 300 MHz and 3 GHz, usually 315 and 433.92 MHz with respect to TPMS technology.

VIN (Vehicle Identification Number) is a unique code used by the automotive industry to identify individual motor vehicles.

WLAN or Wi-Fi is a local area network that uses high frequency radio signals to transmit and receive data over distances of a few hundred feet; uses Ethernet protocol.

## B - VIN

When using the PRO Series tool, it is important to verify the Model Year you are working on to ensure that you are looking for the proper sensor and are using the proper vehicle COMs when necessary.

By using the vehicle's VIN instead of the manufacture date, you can accurately determine that vehicle's Model Year. Refer to that vehicle's VIN, and locate the 10<sup>th</sup> digit from the left. Use the 10<sup>th</sup> digit to reference the chart below to determine the correct Model Year. The VIN is most commonly located at the base of the windshield on the driver's side, or on the tire placard in the driver's-side door jamb as per the diagram below.

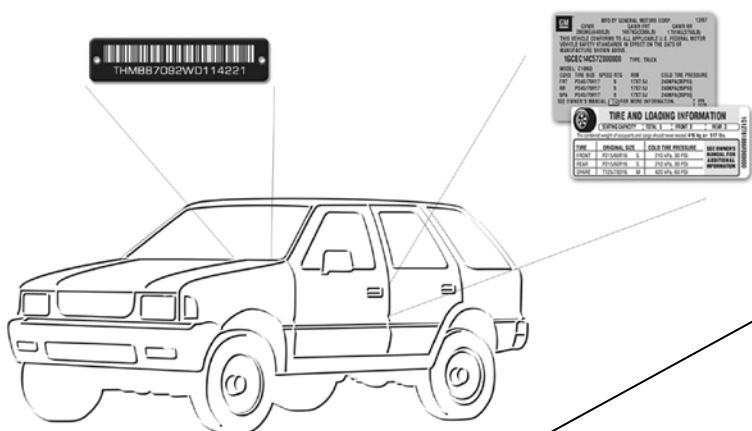

**3VWPE69MX3M169854**

**TIRE AND LOADING INFORMATION**

SEATING CAPACITY | TOTAL 88 | FRONT 8 | REAR 88

The combined weight of occupants and cargo should never exceed **XXX kg or XXX lbs**.

TIRE	ORIGINAL SIZE	COLD TIRE PRESSURE	SEE OWNER'S MANUAL FOR ADDITIONAL INFORMATION
FRONT	P235/60R17XL	200 kPa, 29 PSI	
REAR	P235/60R17XL	200 kPa, 29 PSI	
SPARE	P235/60R17XL	200 kPa, 29 PSI	

10 Digit in VIN	YEAR
2	2002
3	2003
4	2004
5	2005
6	2006
7	2007
8	2008
9	2009
A	2010
B	2011
C	2012
D	2013
E	2014
F	2015
G	2016
H	2017
J	2018
K	2019

## C - FAQ & Troubleshooting Guide

**The tool is set up correctly for make/model/ year, but the tool does not work on the sensor.**

Answer: Check [tool positioning](#). Use the [10<sup>th</sup> digit of the VIN](#) to verify the vehicle's Model Year. TPM sensor could be faulty, or the vehicle could have the incorrect sensor type installed.

**I have a faulty sensor and the dealership gave me a new one, but it will not program to the vehicle.**

Answer: The dealership may have provided the wrong sensor. Many vehicles of the same model might have 2 or 3 possible sensor variations to accommodate high and low pressure ranges, frequency, etc.

**I just rotated the vehicle's wheels. Do I need to relearn the sensors to the vehicle?**

Answer: Yes. Bartec recommends that you ALWAYS perform a [relearn](#) after a tire rotation.

**The tool won't turn on.**

Answer: Make sure battery is fully charged. [Charge your tool](#) for 4+ hours and retry powering it on.

**The option for "Send Data" does not appear under Send/Store Data.**

Answer: Bluetooth is not [enabled](#) under My Tool > Bluetooth.

**I send data to TPMS Desktop, but nothing appears in the Audit section.**

Answer: Verify the [Date/Time](#) is properly set on the tool (located under My Tool > Settings) and on your PC.

**I just updated. What's new with my tool?**

Answer: Read the latest [Software Release Document](#) to review the latest updates Bartec has made to your software.

**How do I know if the sensor battery is low?**

Answer: In some cases, you won't know since the battery might be too low to even transmit. If the sensor spec allows, when the sensor battery gets low, it will transmit a status and the Bartec tool will prompt with a Low Battery icon.

**I installed a sensor and I can't read it.**

Answer: Did you use a programmable sensor? If so, you may have forgotten to program it. Programmable sensors usually must be programmed prior to reading.

## D - COMS Error Troubleshooting

If you are having a problem or error during the COMS process, follow these steps before calling Technical Support:

### 1. Check vehicle ignition

The vehicle's ignition must be in the Key On position for the vehicle's communication (COMS) process to finish.

### 2. Check cable-to-tool connection

Ensure the cable is connected at the DB15 port on the tool, and that the thumb screws are finger-tight.

### 3. Check cable-to-vehicle connection

Ensure the OBDII cable is connected securely to the vehicle's OBDII port. Inspect the cable for bent and/or missing pins.

### 4. Verify Make, Model, and Year

COMS can change from Model to Model, and Year to Year. Verify the tool is set up with the proper MMY.

### 5. Verify tool power level

If your tool has a low battery charge, this may affect the COMS process. Charge the tool and try again with a full battery.

## LIMITED WARRANTY and REPAIR

Bartec products are guaranteed for a period of 1 year from the original date of purchase (either from the factory or authorized dealer). In order for your warranty to become active, you must register your tool with Bartec USA by mailing in the warranty card or registering on our website. We warranty that the tool will be free from defects in material and workmanship, when properly used. THIS WARRANTY APPLIES ONLY TO THE ORIGINAL CONSUMER PURCHASER OF THIS PRODUCT. In the event of a defect, Bartec USA LLC will, at its discretion, repair or replace the tool with a product of like kind or quality, which may be new or reconditioned. The repaired or replaced product will be warranted for 90 days from the date of return shipment, or for the balance of the original warranty, whichever is longer. Claims of all defects must be submitted within 30 days of occurrence, and verified by an authorized Bartec representative.

### **Limitation of Liability:**

Under no circumstances shall Bartec be liable for any special, consequential or incidental damage arising from any defect in products manufactured or sold by Bartec outside of the responsibilities expressed by this warranty. No person, distributor or representative of Bartec is authorized to make any representations on behalf of Bartec beyond those expressly stated in the applicable literature. Bartec reserves the right to make design and other changes, modifications, or improvements without any obligation to install the same on previously sold or delivered products.

It is expressly agreed that the liability of Bartec is limited, and we do not function as an insurer. The remedies set forth in this warranty shall continue the exclusive remedies available to the purchaser or user and are in lieu of all other remedies expressed or implied. The liability of Bartec, whether in contract, or in tort, under any warranty or otherwise, shall not exceed the selling price by Bartec or the manufacture of the particular product made, sold, or supplied by Bartec.

### **Exclusions:**

The following items are excluded from the warranty coverage:

- periodic maintenance and repair or replacement of parts due to normal wear and tear
- batteries (except internal)
- finishes
- service performed or attempted by anyone other than an authorized Bartec service technician

*Opening, dismantling or repairing of this product by anyone other than an authorized Bartec technician will void this warranty.*

This warranty does not apply to damage or loss by and or all the conditions:

- Freight Damage
- Decals, Overlays or Decorative Items
- Misuse or misapplication or failure to follow the directions, or failure to follow cautions or warnings on product, operation, service guides, etc.
- Minor stress cracks in surfaces that are considered cosmetic and have no effect on tool function or performance or safe use.
- Any damage related to fire, accident, misuse, acts of war, disaster, terrorism, or God.

It is expressly agreed that the liability of Bartec limited WARRANTY IS EXCLUSIVE. BARTEC DISCLAIMS ANY AND ALL OTHER WARRANTIES.

Bartec USA, LLC does its very best to insure the accuracy of the information contained in work instructions, but cannot be responsible for errors or omissions by third party sources.

This warranty is exclusive to the original purchaser of the tool and is not transferable.

## LIMITED WARRANTY and REPAIR (Continued – 2)

### Repair Terms:

To obtain service for your Bartec tool the purchaser must obtain a Return Materials Authorization (RMA) number from Bartec USA customer service prior to shipping. Bartec shall not be liable for any expense incurred by purchaser in order to remedy a defect without prior authorization. To obtain your RMA number, you will need to provide at a minimum the follow: 1) Model and Serial Number, 2) Supplier from which the tool was purchased 3) Date of purchase, 4) Description of problem, how and when it occurred. Please note that Bartec USA may attempt to have you try some things in the field prior to issuing a RMA number to determine if the tool does need to come back. The purchaser must return the product per the instructions on the RMA form.

Bartec USA may refuse your delivery if the RMA number is not clearly marked on the outside of the box.

Bartec USA reserves the right to refuse to provide service free-of-charge if the sales receipt is not provided or if the information contained in it is incomplete or illegible or if the serial number is altered or removed. Bartec USA is not reasonable for any losses or damage to the product incurred while the product is in transit or is being shipped for repair.

**IMPORTANT NOTE: IN ORDER TO COMPLETELY & PROPERLY DIAGNOSE THE ISSUE THE ENTIRE KIT MUST BE RETURNED**

### Warranty Repair Freight:

Inbound freight costs for warranty repair tools will be the responsibility of the customer. Freight costs out bound will be paid by Bartec and returned in the same method as the inbound.

### Non-Warranty Repair Freight:

Inbound freight costs for non-warranty repair tools will be the responsibility of the customer. Outbound Freight costs will be paid by Bartec and returned UPS ground.

### Freight:

#### Warranty Repair:

Inbound freight costs for warranty repair tools will be the responsibility of the customer. Freight costs out bound will be paid by Bartec and returned in the same method as the inbound.

#### Non-Warranty Repair:

Inbound freight costs for non-warranty repair tools will be the responsibility of the customer. Outbound Freight costs will be paid by Bartec and returned UPS ground.

### MECHANICAL TOOLS & CABLES:

#### Warranty:

Bartec MECHANICAL Tools and cables are warranted for 180 days from the ORIGINAL purchase date (from an AUTHORIZED DEALER). When properly used and maintained, Bartec will warranty the tool to be free from defects in material and workmanship. The Warranty applies ONLY to the ORIGINAL OWNER and is not transferable. In the unlikely event of a defect, Bartec will at its discretion repair or replace the tool with a product of like kind or quality which may be new or reconditioned. The repaired or replaced product will be warranted for 90 days from the date of the return or the balance of the original warranty, whichever is longer. Claims of ALL defects must be submitted within 30 days of occurrence and verified by an AUTHORIZED BARTEC agent or representative.

**TOOL REGISTRATION FORM**

*Only complete and send this form if you do not have access to register your tool online.*

First Name: \_\_\_\_\_ Last Name: \_\_\_\_\_

Company: \_\_\_\_\_

Address: \_\_\_\_\_

City: \_\_\_\_\_ State: \_\_\_\_\_ Zip: \_\_\_\_\_

Phone #: (\_\_\_\_\_) \_\_\_\_\_ - \_\_\_\_\_

Fax #: (\_\_\_\_\_) \_\_\_\_\_ - \_\_\_\_\_

Date of Purchase: \_\_\_\_/\_\_\_\_/\_\_\_\_ Supplier Purchased From: \_\_\_\_\_

Tool Serial Number: \_\_\_\_\_ Model: \_\_\_\_\_

Email Address: \_\_\_\_\_

Desired User Name: \_\_\_\_\_

Desired Password: \_\_\_\_\_

I would like to participate in the SD card program (understanding I will only receive 2 cards per year):

Detach and mail to:  
**Bartec USA**  
**44231 Phoenix Drive**  
**Sterling Heights, MI 48314**

Or fax to:  
**(586) 323-3801**

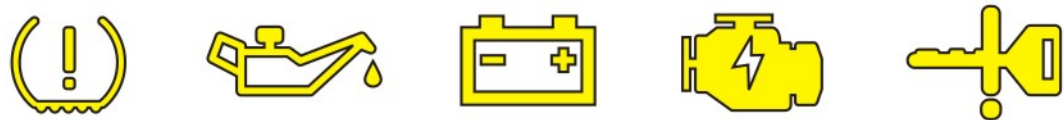

**Solutions for better vehicle service**

Bartec USA, LLC  
44231 Phoenix Drive  
Sterling Heights, MI 48314  
(866) 407-8767